

A RELUCTANT RELATIONSHIP
THE HISTORY OF THE CUMBERLAND GROUP OF
SURVEYORS 1963 – 1998

Keith B. Cadogan M.I.S. Aust. Registered Surveyor, Cumberland Group Representative and Member, History Subcommittee, The Institution of Surveyors New South Wales Incorporated.

Sydney, September, 1998.

PROLOGUE

When Royston Lowe, current Chairman of the Cumberland Group of Surveyors, asked me to undertake this project earlier this year (1998), he prefaced his request with the words: "Are you sick of researching surveying history yet?"

The answer must have been: "No", but the thing that influenced me to accept was that I have always been interested in oral histories, and I believed that this was an ideal way to handle this project.

I started with a list of (alleged) founding members obtained at meetings of the current membership of the Cumberland Group. History has been described as a collective memory, so initially I thought to get those listed together to record their joint recollections.

It became apparent that most of the men listed were separated in membership time and that most of them had very minimal recall of Group matters, so that unfortunately an oral record was not practical or appropriate.

In any case, by this time I was well and truly committed to the project. It became apparent that there were a number of significant events during the Group's 35 years of existence These are:

- Its formation in 1963.
- The expansion in membership and its formation of the Association of Consulting Surveyors in the late 1960s.
- Its near demise in the early 1970s and subsequent resurrection in the late 1970s.
- Formal affiliation with the Institution of Surveyors NSW Inc. in 1985.
- The commencement of Group annual mid-year seminars in 1991.
- The ongoing relationship with the same Institution at the end of the century.

Research also disclosed that a Group history had been mooted more than once in the past, the last time being on the occasion of its thirtieth anniversary in 1993. On the face of it, these earlier times would have been much better times to have started, because there would, or should, have been still alive, people with better memories and possessing more written records available to research.

In all cases the source of information has been acknowledged. However, it should be apparent to anyone reading this history that there are gaps, some of which are specifically referred to, and quite possibly errors and/or omissions. It is my hope that this first edition will produce information to help eliminate these gaps, errors or omissions. Anyone able to contribute in any way, no matter how small, is invited to do so, by contacting members of the Group Committee or the author.

CONTENTS

PROLOGUE	2
ACKNOWLEDGEMENTS	4
LIST OF FIGURES.....	5
CHAPTER 1 1963 – 1967....	6
CHAPTER 2 THE FORMATION OF THE ASSOCIATION OF CONSULTING SURVEYORS	10
CHAPTER 3 1970 – 1985....	15
CHAPTER 4 THE RELATIONSHIP BETWEEN THE CUMBERLAND GROUP AND THE INSTITUTION OF SURVEYORS NEW SOUTH WALES INCORPORATED...	18
CHAPTER 5 1986 – 1998....	22
APPENDIXES.....	26

ACKNOWLEDGEMENTS

I was assisted in various ways by Bert Cawthorne, Vern Clements, Roy Lowe, Barry McLeod, Greg Oxley and Heather Phillips.

In addition, Bert Cawthorne, Vern Clements, Roy Lowe, Barry McLeod and Greg Oxley agreed to read and comment on the draft.

Valda Cadogan did the proofreading.

For support in producing and promoting this history, I must thank the Cumberland Group of Surveyors and in particular my fellow Group Committee members, Roy Lowe, Michael Parkinson, Gerard Junek, John Brock, Ron Cumming, Bob Hanna, Brian Mc Kinlay, Greg Oxley and Barry.Yardley.

I must also thank the Institution of Surveyors New South Wales Incorporated and in particular Heather Phillips for assistance in promoting and distributing this history through its Internet site.

LIST OF FIGURES

Figure 1. Extract from *The Australian Surveyor* September, 1963, pages iv and v.

Figure 2. Extract from *The Australian Surveyor* September, 1963, pages vi and vii.

Figure 3. Extract from *The Australian Surveyor* December, 1963, pages ii and iii.

Figure 4. Extract from *The Australian Surveyor* December, 1963, pages vi and vii.

Figure 5. Extract from *The Australian Surveyor* December, 1963, pages viii and ix.

Figure 6. Vern Clements, 'then'.

Figure 7. Vern Clements, 'now'.

Figure 8. Wal Ayling, 19?? (See Appendix A)

Figure 9. Barry McLeod, 1993.

Figure 10. Bert and Betty Cawthorne, 1997.

Figure 11. Bill Backhouse, 1994/95.

Figure 12. Cumberland Group Committee, 1997. From left: John Brock, Barry Yardley, Brian McKinlay, Keith Cadogan, Bob Hanna (Treasurer), Gerard Junek, Greg Oxley, Michael Parkinson (Secretary), Roy Lowe (Chairman), Ron Cumming.

CHAPTER 1 1963 – 1967

In 1963 two New South Wales (NSW) surveyors based in Parramatta "conceived the idea of having a group to allow the local practitioners to get a better knowledge of each other and to co-operate in enhancing the interests of the profession."

They met after hours in the office of one them and "agreed in principle and ... decided to approach all other local surveyors."

These co-founders of the Cumberland Group (the Group) were Walter Thomas Edward Ayling and Vernon Rupert Clements. The meeting took place at Vernon Clement's office, 71 George Street, Parramatta, and the words quoted here are his.

The approaches to "all other local surveyors ... (they) did and with success except in one or two cases in which no merit was seen in the proposal."

They "held an initial meeting at which it was proposed that a group should be formed with Wal Ayling as President and I (Vernon Clements) was asked to continue as secretary." This meeting took place on 13th December, 1963.

To quote again from the founding Group Secretary: "The foundation members to the best of my recollection were Wal Ayling, Vince Exley, Ken Hainge, John O'Keefe, and myself. I had a small notebook in which minutes of meetings were kept which should be around somewhere if the first records were kept. Other members were admitted as time went by but they were not founding members."

Unfortunately the small notebook has not come to light, which is most unfortunate because, despite contacting the other three surviving founding members, I have been unable to glean much Group information at all for the first few years (for example, numbers and names of those attending, office bearers), and this written record would have been invaluable in filling this gap.

I live in hope that this narrative may yet produce the notebook in question, which would appear to have been passed on to succeeding secretaries. I do know that the initial meetings were held monthly, that there was apparently no need for a treasurer, and that meetings were notified verbally.

Vernon Clements went on to say that "I am unable to locate my office notebooks and presume I destroyed them after cessation of practice. ... In my possession are most copies of the Institution Journal from the early forties until it was decided that Hon. Members should be deleted from the mailing list also I have quite a lot of copies of the old NSW Institution Journals. If you know of anyone who would be interested in having these I would like to hear from them so that these old records will escape destruction upon my demise."

I am pleased to pass on this request and to include two images of Vernon Clements ('then', See figure 1 and, 'now', See figure 2.) — he being the only contributor to this history who could produce any photographs of himself. This probably indicates that most surveyors are so busy they cannot pause long enough to waste time being photographed, or that their images are so ugly they cannot bear to have them recorded.

Vernon Clements was mostly a sole practitioner with offices at Parramatta and Castle Hill, employed two or three people, operated in metropolitan and country areas using firstly a vernier theodolite and level, both by Messrs Cooke, Troughton and Simms, then later an optical glass circle theodolite and finally electric distance measurement (EDM) equipment. He sold his practice in 1979, the same year he last attended a Group meeting. He now lives in retirement with his wife in a granny flat at his daughter's home in Jillyby NSW. He describes himself as "an octogenarian", but fortunately for us, he is one with an excellent recall. He suffered a stroke just before Christmas this year (1998), but subsequently still managed to read a draft of this history, and make corrections and comments on it.

With regard to the other co-founder, Walter Thomas Edward Ayling was born on 8th July, 1929, became a Member of the Institution of Surveyors on 10th August, 1951, and died in 1997 (See Appendix A).

As far as the remaining three founding members, Vince Exley, Ken Hainge and John O'Keefe are concerned, Vince Exley now lives at Airlie Beach in Queensland. How he can bear to spend his time there after practicing in beautiful downtown Parramatta from 1955 until 1995 is difficult to understand (in modern parlance, not). An intelligent Group member suggested that I should go to his present abode to interview him and although I was prepared to force myself, the other short-sighted Group Committee members could not see the obvious virtue in this course of action. Vince Exley acknowledges that he was a founding member of what was originally a fellowship group but he cannot recall any dates or details.

During the 40 years his practice was in Parramatta he operated at one time all over NSW as well as into Queensland. His own practice employed 19 people up until the time he combined with most other survey firms in Parramatta to form Exley, Smith, O'Keefe and Partners, which at one time employed 70 people, specialising in subdivision design, engineering design, town planning, environmental impact studies as well as peg-out and identification surveys. His continuing interest in technology meant that he believes he used the first Geodimeter and Hewlett Packard (HP) calculator. He played a leading role in the formation of the Association of Consulting Surveyors (ACS) — more on this later.

Ken Hainge is still a Registered Surveyor and still practices at a Parramatta survey office. Although very co-operative, he cannot recall any details of the Group's formation.

John O'Keefe became part of the combined survey firm in Parramatta mentioned above and was also a Registered Surveyor until the latter part of this year (1998) when he received his Emeritus Certificate. He now lives at Forest Reefs in NSW and was recently appointed Legislation Advisor to the Board of Surveyors of NSW. He made it plain to me both in person and in writing that he was happy to assist in any way he could in the production of this history. He also played a leading role in the formation of ACS — again more on this later.

By way of background to the era of Group formation, Figures 4 to 7 inclusive are extracts from two copies of *The Australian Surveyor* of 1963.

It is now necessary to move on to the year 1965 and to acknowledge the following contributions of Barry McLeod to this history: In 1965 "I [Barry McLeod] was invited to lunch at, I think, the

Parramatta Businessmen's Club. I am not sure who asked me but can recall Wally Hunt, Vern Clements, Wally Ayling, Bill Timbs being present. There may have been others but we were at a small table so [there] would not have been many. My recollection was a few of the local practitioners had decided to meet on, I think, a three-monthly basis to have informal chats about surveying issues of mutual concern. As others in the area heard of these meetings and wanted to attend it was mooted to hold evening meetings."

These evening meetings eventuated and were held at the Skyline Motel on the Great Western Highway at Parramatta. It was interesting for the author of this history when the Group held a number of meetings at this same venue last year (1997). A number of attendees told me they remembered meeting there in the past and they remarked how much the panorama had altered.

Barry McLeod recalls that these evening meetings were held every three months, with special meetings on occasions. Members were notified by telephone. Meetings started with a meal and some were conducted while eating. They probably commenced about 6 p.m. About 15 attended these meetings and they included Vince Exley, Deric Finney, John O'Keefe, Jack Menzies, Eric Maronese and others.

The matters they discussed were "Initially matters relating to [survey] practice, (Land Titles Office) LTO requirements, and similar topics. As numbers grew, [included were] the problems of [the] education of surveyors, particularly dissatisfaction with the education of surveyors at (University of NSW) UNINSW School [of] Surveying. Probably arising from this came concern at the lack of action by the NSW Division of (The Institution of Surveyors, Australia) ISA (ISNSW, or the Division) in the addressing of education and other problem issues."

Barry McLeod remembers that "The Group was always viable. Members paid for their meals and that was the only cost. The treasurer's task was to collect the meal money and pay the motel. For some years no one paid to belong. The only list was for the Chairman, Secretary and Treasurer to be able to ring the last attendees to advise the venue and time for the next meeting. Once a year an election was held for these positions. The only criteria was office holders and those with voting rights were members of the Institution (more on this aspect later). The numbers grew very quickly. I do not recall it was an objective of those who commenced meeting to create a large organisation. Enclosed is a phone list when I was chairman in 1967. Although [there are] only 55 on this list, I believe some later meetings exceeded 100 attendance."

The 1967 telephone list referred to is included as Appendix B. It is a rare gem of recorded information on Group membership during this period.

Barry McLeod's observations on why the Group was viable in the late 1960s are interesting: "I was invited to join others in 1965 who at that time understood a lot more of the problems relating to the surveying world than myself. I cannot recall any discussion of a subversive organisation being formed. My own opinion is the original meetings were being held to informally discuss current issues by members of the Institution in the Parramatta and immediate area. When the word got about a few were having such meetings it led to a virtual explosion of interest from surveyors over the greater metropolitan area. There had been a drift away from the central business district for the location of practices for some time and the Institution as a venue was becoming more remote. Within the first few years of the group emergence as a forum it became apparent many members

were of the view the Institution was not representing the surveying profession in a manner appropriate for the times.

"This was particularly evident in matters of education, low fee charging, and the standing of surveying generally in the community. The Divisional Committee was seen by many as an old boys club and lobbying within the group managed to obtain election of some Cumberland members onto the Committee.

"So although formed for 'a quiet chat' type of group it has evolved quickly into a political vehicle."

Barry McLeod still attends Group meetings. His photograph, taken at the time of his Presidency of ISNSW in 1993, is shown in Figure 9. The practice in which he still operates commenced in 1964 with five employees and two field parties, comprising two persons, sometimes three. They carried out mainly identification surveys and starting out into subdivision work in the greater western suburbs, using theodolites, wire chains, level and staff, and an Odner calculator. Vehicles used were a Valiant station wagon and a Ford panel van. An eight or nine hour day was worked Monday to Friday, with weekend work if needed on construction sites.

CHAPTER 2. THE FORMATION OF ASSOCIATION OF CONSULTING SURVEYORS (ACS).

Because he was Group Chairman at the time, Barry McLeod's comments on this event are very relevant:

George Moore of Wallis and Moore addressed a meeting with the proposition that an independent group be formed to represent the interests of private practitioners. I was the Chairman at the time in 1967. It was argued the Institution could not represent the interests of both employed and employee surveyors in matters of fees and awards. The Group passed a motion that discussions about this matter be requested with the Divisional Committee. After some period this eventually led to a special meeting of the NSW Division being called where members voted to form both the associations for Consulting Surveyors and Employee Surveyors on the provision members were members of the Institution.

I can remember George Moore arguing for open membership but many at Cumberland believed if that were proposed neither organisation would be voted in. This was in a period of changing times when practice and employment were being subjected to industrial legislations which required separate representation.

Although there was great division on this issue within the Institution opposers were unable to offer any practical solution.

Bert Cawthorne (more on Bert's contributions to the Group later) had these comments to make about the origins of ACS:

I enjoyed being a member of the Cumberland Group and was secretary for about five years and was proud to have a part in building up the membership. During this time, we had to repeatedly inform the Institution that we were not opposed to them, but were of the opinion that we should all work together for the overall good of the profession. Even though the Cumberland Group was the birthplace of the ACS, it was at no time intending to separate itself from the Institution. The ACS always regarded itself, and still does, as being a part of and a co-operating body of the Institution.

Thanks to Bert Cawthorne providing me with a copy, I became aware that June Brand, a former Executive Secretary of ACS, had already written a history of ACS. This history clearly outlines the role played by the Group in the formation of ACS, as well as the Group members who played leading roles. For that reason, I include it in its entirety:

HISTORY OF THE ASSOCIATION OF CONSULTING SURVEYORS

NEW SOUTH WALES

Part 1 - Formation and Administration

The occasion of the Association's move into its own small suite of offices represented a milestone in the development of the Association and prompted a review of the events leading to its formation and of its achievements since.

The impetus to form the Association came from the Cumberland Group whose members saw the need for a group to look after the various aspects of practice peculiar to the private sector and a letter was received by the council of the N.S.W. Division of the Institution from the honorary secretary of the Cumberland Group, Mr. W.T. Ayling, suggesting discussion with council on proposals to form an Association of Consulting Surveyors. The president of the Institution at this time was Mr. E.F. Hunter and the chairman of the Cumberland Group, Mr. A.B. McLeod.

A committee was convened by Mr. J.P. O'Keefe to examine the proposal and at division council meeting of 7th April, 1967, the committee presented its report recommending that the principle of the formation of a body within the Institution to represent private practicing surveyors was desirable. Precedent already existed in South Australia where the Practicing Surveyors' Association of South Australia had been formed in 1958 and in Victoria which in the preceding year (1966) had formed a Private Practice Panel, the aims and objects of both of these bodies being very similar to those suggested for the proposed Association of Consulting Surveyors.

Following a special meeting of division council in August, 1967, at which the proposals were discussed, a multi-purpose questionnaire was circulated to all members of N.S.W. Division which included the following questions:

- i) If you are a surveyor in private practice do you favour the formation of an Association of Consulting Surveyors within the Institution?
- ii) If you are an employee surveyor, are you in favour of the formation of an employee association within the Institution?

The results, published in the Bulletin in February, 1968, were:

Question I): Yes - 81, No -20. Question ii): Yes - 93, No. - 50.

The formation of the Association was discussed in detail at a special meeting of the N.S.W. Division Council on 19th January, 1968, at which, after some contentious discussion, it was resolved - "That this council approves the formation of a Consulting Surveyors' Association and approves in principle the proposed rules as submitted, subject to such amendments as will ensure that the Association will conform with the stated policy of the Institution of Surveyors, Australia." It is interesting to note here that the name had been changed around to Consulting Surveyors' Association. A committee of three was subsequently formed to consider a draft constitution, this committee consisting of Messrs. J.P. O'Keefe, R.B. Alderton and E.F Hunter.

On 2nd August, 1968, council resolved - "That council recommended to the general meeting on 8th November, 1968, that the Consulting Surveyors' Association be formed with the rules as presented herewith."

It is understood that the November 8 general meeting was a stormy affair at which, after a close vote supporting the formation of the Association, it was finally resolved to conduct a postal ballot to decide the issue.

In the December, 1968, Bulletin the case for and the case against the formation of the Association were set out by private and public representative groups respectively. The Cumberland Group also formulated a series of papers discussing the immediate aims and reasons for forming the Association.

One of the main fears apparently held by the objectors at the time was that the formation of the Association would divide the Institution and also cause increased cost to its employee members, of whom there were a majority. Those promoting the formation of the Association felt that these fears would be unfounded as long as the Association were formed under the umbrella of the Institution.

It was envisaged that the Association would direct itself to the more material (commercial) aspects of practice of special interest to surveyors in private practice whilst the Institution would continue to stress the cultural, scientific, educational and social aspects. It was mooted that "with the Institution growing in numbers and complexity, the present system of councillors voluntarily trying to cope with all the necessary business could not keep up with the demand; it was envisaged that a Professional Surveyors' Association (for employee surveyors) and a Consulting Surveyors' Association, both operating under the mantle of the Institution in a spirit of mutual co-operation, could take a great deal of the load from the divisional council and make appropriate recommendations to council".

It is also worth quoting here from one of the Cumberland Group papers promoting the formation of the Association within the Institution. It says, in part, that "It is believed we are all proud of the Institution, of what it stands for, of what it has achieved, of the exertion that a great number of members have made to further the Institution's objects . . . , all of these things are part of the spirit of surveying and part of the Institution and nothing should be done to detract from this spirit or the Institution in any way. It is envisaged that the Association will greatly benefit the Institution if for no other reason that it will take on the task of fulfilling the consulting surveyor's material needs and make the way clear for both his and the employee surveyor's greater enjoyment of the Institution from a cultural, scientific and social point of view."

In January, 1969, the results of the postal ballot to decide the formation of the Association were announced: For - 171, Against - 106, and action was taken to form an interim executive comprising Convener: Mr. J.P. O'Keefe, Committee: Messrs. W.G. Hunt, W.T. Ayling, J.E. McNaughton and J.C. Stevenson.

By April, 1969, the application form had been prepared and issued and by the council meeting of June, 1969, 93 applications had been received. Arrangements were made to reimburse costs to the Institution and it was agreed that no further costs would be debited to the latter.

In May it was resolved to change the name from the Consulting Surveyors' Association to the Association of Consulting Surveyors to avoid conflict with the Country Surveyors' Association.

The inaugural meeting of the Association was held on 2nd August, 1969, being attended by approximately 60 members. The first executive was elected, being:

Chairman: J.P. O'Keefe; Committee: W.G. Hunt, V.K. Exley, A.S.J. Hunter, J.M. Monteath.

Mr. E. Berger, a public relations officer, was appointed executive officer.

It is worth noting here that up to this time moves had also been made to form the Employee Members Committee and at division council meeting of January, 1970, the composition of that committee was set.

Mr. John O'Keefe retired from the chair at the second annual general meeting in March, 1971, when Mr. V.K. Exley succeeded him.

In April of the same year moves were initiated to replace the executive officer, Mr. Berger, and, a special meeting of the executive called to consider alternative secretarial services. At the following executive meeting it was resolved "that the committee of the N.S.W. Division of the Institution be approached with a request that the Divisional Office handle our secretarial duties on a time-cost basis". This was accepted by Division and in May, 1971, Mrs. J.M. Brand was engaged by N.S.W. Division to assist in the office two full days per week and one night per month on A.C.S. MATTERS, Mrs. Brand's wages and an annual overhead fee being charged to A.C.S.

This arrangement continued in principle until the present time and the Association's move to its own small suite of offices as a tenant of the Institution of Surveyors N.S.W.

(Part II to be issued at a later date will outline the activities and achievements of the Association from the time of its formation.)

JUNE BRAND, Executive Secretary.

The Cumberland Group, as it existed at that time, provided the core of interested individuals who drove the cause of creating ACS to a successful conclusion. No similar core of interested individuals existed to drive the cause of creating the proposed Association of Employee Surveyors, and it is significant that it never eventuated.

On a personal note, I well recall attending, in company with a number of my colleagues at the time, the special general meeting of the Division held on 8th November, 1968, referred to by Barry McLeod and June Brand. We were all employed in the public sector. The meeting was held at Science House, Gloucester Street, Sydney — the home of ISNSW for many years. It was standing room only, with an overflow into the adjoining corridor. Usually creatures of a solitary nature, it was the largest gathering of surveyors I had ever seen up until that time. Feelings ran high, and as Barry McLeod has so aptly phrased it: "there was great division on this issue". Generally, the division was between private practitioners and employed surveyors, a group that included me.

From a different perspective, the results were traumatic and divisive. I (for one) came away from the meeting convinced firstly that ISNSW had changed its focus away from its traditional role, and secondly that it had become devoted solely to the interests of private surveyor principals. Consequently, I resigned forthwith from the Institution, but that (to coin a phrase) is another story.

CHAPTER 3. 1970 – 1985.

It is now time to formally introduce Bert Cawthorne and acknowledge his contributions to the Group and to this history.

Bert Cawthorne joined the Group in 1970. He was introduced by Bernie Moriarty. Meetings were held monthly on Wednesday between 7pm and 10pm at the Masonic Club, Parramatta. About eight people attended. They included Chairman Bernie Moriarty, Secretary Wal Ayling, Treasurer Bob Degotardi, Bert Cawthorne, Vernon Clements, Barry McLeod and John Sunter.

In Bert Cawthorne's words the meetings discussed "Generally matters affecting the Private Consulting Surveyor vis-à-vis the Institution together with items raised by the Surveyor General and various Government Bodies." He believes the Group was formed "to allow the private consulting surveyor to express his needs and opinions with a degree of authority in matters affecting the profession." Meetings were notified by word of mouth and "the Group was viable due to the enthusiasm of the few surveyors attending."

The size of the attendances and Bernie Moriarty's chairmanship at this time are interesting. Bernie Moriarty contacted me about this history in mid 1998 and, amongst other things, told me that the very first time he attended a Group meeting it was mooted to disband the Group because of poor attendances. He felt moved to protest strongly against this course of action and found himself Chairman by the next meeting.

Bert Cawthorne continues: "I became secretary in 1971 and began a promotional campaign by phoning several surveyors and inviting them to attend. The meetings were informal in that we met for dinner at the Parramatta Masonic Club and discussed the business of the evening after dinner. By constantly phoning a number of surveyors, numbers grew to about 60 members over a period of four years. During this period I organised speakers to address the members and also organised visits to various venues such as the Army School of Artillery Surveying and the Navy Hydrographic School at H.M.A.S. Penguin, also the NSW Police Forensic Science Laboratory. Member's wives were invited to accompany their husbands on these occasions which proved to be very popular. One Sunday visit was made to H.M.A.S. Penguin and families were invited. The R.A.N. entertained the children of members by boat rides, tennis and outdoor games.

"Two other most interesting evenings were a talk and slide show by Don More on his survey experiences in Indonesia — greatly enjoyed by the members and wives. The other very interesting evening was a joint talk by David Lambden who was the last surveyor to undertake work in the Arctic Region by the use of sled dogs as his only means of transport, and Bruce Smith, who spoke of his experiences in the Antarctic Region.

"Other interesting evenings were talks by the NSW Ombudsmen, Peter Angus Leppan, and heads of various State and Local Government organisations."

Bert Cawthorne's campaign revitalised the Group and set the pattern for the future, especially regarding the advent of Continuing Professional Development (CPD) activities. His involvement in Group affairs continued for many years after he was a member of the Group Executive. For

example, he was a principal player at the time of formal affiliation with the Division in 1985, as will become apparent later.

Bert Cawthorne, always accompanied by his wife Betty, still attends Group Annual General Meetings (famous for the brevity of their formalities). Their images are included as Figure 10. He supplied me with this background information: "At the time of joining the Group I was NSW Manager for the surveying instrument company Wild Australia Proprietary Limited. Subsequently I became National Manager for Australia and the South Pacific. My main objective was the promotion and sale of the company's surveying and photogrammetric equipment and, because of my experience in the United Kingdom, India and Papua New Guinea, I was able to advise and consult with developers of major projects such as the Bougainville Copper Mine, the Monasavu hydro-electric dam in Fiji and major development highways in Papua New Guinea".

I can vouch for the effectiveness of Bert Cawthorne's persistence in recruiting Group members. I used to contact, or meet him, periodically, in connection with the purchase, performance or maintenance of surveying equipment. Invariably at some time during the discussion he would quietly suggest I should join the Group. For a long time I declined because I believed that the Group at that time represented the interests of private practitioners only, not entirely an erroneous belief, given its history. After I eventually succumbed to his low-key persistence and joined, he invariably telephoned to tell me about the next meeting. He would never leave a message or ask for me to ring back, but would keep trying until he spoke to me personally.

It is now time to introduce another two rare gems of recorded information for this period (courtesy of Barry McLeod): minutes of a Group Committee meeting on 15th February 1978, and minutes of a Group General Meeting on 18th April, 1979, both held at Parramatta Masonic Club. A. J. Sunter was the Chairman on both occasions, and those present included W. Taylor, B. McLeod, B. Moriarty and B. McKinlay on the first occasion, and R. S. Lovegrove, W. Rein, E. Maronese, D. Timbs and B. Timbs on the second (unfortunately the list of those attending then was no longer attached).

In the middle of trying to research this project, Ron Cumming, a fellow Group Committee Member, announced that he had some Group records in his possession. They turned out to be some Group minutes and correspondence for the decade 1982 to 1992. I live in hope that others may come forward after reading this, with similar treasure troves of recorded information for earlier periods, although there is no such possibility for subsequent times, for reasons that will emerge later.

The following is a résumé of office-bearers and financial members for the years 1982 to 1985 gleaned from these records (this résumé is continued in Chapter 5):

Annual General Meeting 17th November, 1982: retiring Chairman D. Timbs; retiring Secretary C. Ryan; new Chairman M. Archbold; new Secretary C. Ryan; Treasurer G. Wren (this executive remained in office during 1983 and 1984); new Committee J. Bowden, B. Cawthorne, J. Sunter, D. Timbs.

Financial members (28) 1984: M. Archbold, W. Backhouse, J. Brock, M. Buttsworth, G. Caddey, B. Cawthorne, Craig and Rhodes, R. Cumming, B. Green, J. Higgins, B. Homann, A. Keighran, D.

McArthur, B. McLeod, R. Martin, D. More, M. Morgan, B. Moriarty, G. Murray, C. Ryan, I. Shepherd, P. Strudwick, J. Sunter, D. Timbs D. Warry, S. White, G. Wren, P. Youdal,.

Annual General Meeting 13th November, 1985: retiring Chairman W. Backhouse; retiring Secretary C. Ryan; new Chairman W. Backhouse; new Secretary P. Strudwick; Treasurer G. Wren; new Committee J. Bowden, B. Cawthorne, J. Sunter, D. Timbs.

CHAPTER 4. THE RELATIONSHIP BETWEEN THE GROUP AND ISNSW.

In the words of one of the Group co-founders (Vernon Clements): "I advised the Institution of the proposal [to form the Group] and slightly reluctant approval was forthcoming."

These prophetic words characterize the relationship that still obtains between the Group and the Division, and incidentally are the source for the title to this history. There has been, and still is, a "slightly reluctant approval" on both sides of the relationship.

However, when I asked Vernon Clements (what he thought) about the affiliation of the Group with the Division, he replied: " I thought they always were." I now believe that throughout its existence, Group members always believed affiliation to be a fact, although formal affiliation did not occur for a long time, but only because of the reluctance, and Articles of Association, of, the Division. As proof of this belief, the usual letterhead used routinely by Group Secretaries is relevant (for example, letter dated 28th June, 1978 by A. Cawthorne (See Appendix C). The same former secretary also believes that formal affiliation did not occur sooner because of resistance by the Division. Also relevant are the comments (previously quoted) by Barry McLeod that the only criterion for Group membership, and voting rights for the election of office holders, was membership of the Institution.

Barry McLeod's comments on affiliation are also germane: "Initially as a lunchtime chat group there was no need [for affiliation]. Once the Group became politically active some on Divisional Committee recognised a need for the channeling of the energy of the Group to the overall good. At that time divisional rules allowed recognition of some groups, e.g. Hunter Manning, Country Surveyors, various Government employee representation.

"The representation of other geographic locational groups, particularly in the Sydney region, would be in conflict with the Division's traditional regular meetings which members were able to attend.

"It took many years for the Divisional Council to come to terms with the message that came from Cumberland which was that many members of the Institution desired meeting places which they could access more easily, to be able to meet and discuss issues in an informal and relaxed manner and be provided with greater representation on Committee."

Formal affiliation was proposed by Bert Cawthorne in a letter dated 30th August, 1985, to the Group Chairman, Bill Backhouse (See Appendix D).

A subsequent submission to the Group Annual General Meeting of 13th November, 1985, again from Bert Cawthorne, outlines the complete history of the group's various applications for recognition by the Division from 1963 until 1985 and is included in Appendix E.

A vote on formal application for affiliation was taken at that Group Annual General Meeting on 13th November, 1985. On a purely personal note, I attended and voted at that meeting — in favour of affiliation. The vote was ten in favour, eight against. A copy of the relevant parts of the minutes of this momentous occasion in Group history is included as Appendix E.

Notice of formal acceptance of affiliation by the Division is contained in a letter dated 13th December, 1985. (See Appendix F). The first Group Representative on Divisional Committee was Bill Backhouse. Subsequent Group Representatives included Ron Cumming and Greg Oxley.

..ooOOoo..

At Group meetings I have been asked to explain various aspects of the present relationship between the Groups, the Division and ISA. The easiest way to attempt this explanation is to say that in NSW, the relationship between these three bodies has remarkable similarities to the relationship between the three tiers of government, Local, State and Federal. For example:

- The Groups and ISA are the children of IS Divisions, just as Local and Federal governments are the children of the States.
- Funding is an ongoing problem between the Groups, ISA and ISNSW, just as it is an ongoing problem between the three tiers of government, although there is a difference here inasmuch as ISNSW holds most of the funds, whereas in government, it is the Federal government.
- From the point of view of the average NSW surveyor (if such a creature exists), the Institution is over-governed, is bureaucratically duplicated, and costs him or her more than in other States, just like government in Australia, from the point of view of the of the ordinary New South Welshperson.
- A maximilist republican surveyor (just in case the reader thinks that no such animal could possibly exist, then I confess to qualifying) would see the need to eliminate one of the three tiers from both the Institution and government. In the case of government, this tier is usually perceived to be State government (providing strong regional governments replaced present local governments), whereas in the case of the Institution, this level is usually perceived to be ISA. However, it is relevant to remember that at one time the Division was almost completely moribund, before it was restructured and the Groups formed (where non-existent) and formally affiliated. This action revitalised the Division but does not necessarily mean that Divisions (or States, for that matter) are essential.
- The populations of both the Institution and Australia are ageing, are traditionally conservative, and therefore reluctant, and unlikely, to change.

I became Group representative on Divisional Committee in February, 1995, and remained in that role until October this year (1998). The first meeting I attended was held in the historic Newcastle Town Hall. On the agenda was the ratification of Group Rules. It was proposed to limit the membership of the Cumberland Group to surveyors who either lived or worked in a small number of Sydney Postcode areas, and I refer to the assurances by the Division Executive Officer already quoted in Appendix E at the time of affiliation that "We (the Cumberland Group) would not be bound by areas." The 1995 Division Executive (incidentally including Barry McLeod) genuinely believed that this policy would reduce the size of those Groups perceived as 'strong' (this included the Cumberland Group) and increase the membership of Groups perceived as being numerically 'weaker'.

I had already ascertained that the then current membership of the Group was not large but came from a variety of workplaces and living areas. For example, one of our members was headquartered at Burwood, lived at Newcastle and regularly attended Cumberland Group meetings and met his colleagues on his way home. Another regularly drove down for meetings from his practice at Mt. Victoria. To me the whole thing infringed two of the basic freedoms of our non-existent Bill of Rights, namely Freedom of Choice and Freedom of Association.

To tell any of our Group members that they could still attend our meetings but could no longer be members, was unthinkable. Fortunately, a majority of Divisional Committee members agreed with me, and present Group Rules allow Group members to belong to any Group it is convenient for them to do so.

Incidentally, these rules are being reviewed by a Divisional Sub-Committee at the present time (1998). This review has been brought about by disputes about Group financial autonomy, notably involving the Cumberland Group. I refer to the assurances (quoted in Appendix E) given to the meeting on affiliation by the Division Executive Officer that "We (the Cumberland Group) would remain independent". Although there are four Cumberland Group members on Divisional Committee, including two on Divisional Executive, no Cumberland Group member is a member of this Sub-Committee.

Again there are parallels with the relationship between ISNSW and ISA or between the States and Local Government. There was a very recent confrontation involving power, control and money between ISNSW and ISA, who were attempting to restructure the Institution.

Barry McLeod, who was very closely involved in these matters, sees them in purely audit and legal terms, as follows:

"My recollection is this issue first became a problem after the division's auditors" [who, it should be noted, were deliberately replaced in 1998] "discovered the existence of the individual group bank accounts and advised they had to, by law, bring those accounts into the division's books.

"As the groups were not separate entities and are created from the constitution, the group cash assets are viewed in law as the property of the NSW Division.

"This did not mean the division had to direct or control these funds however if they were not used in accordance with the constitution the division was responsible and there could be taxation and or other legal complication.

"I doubt this issue was explained to all involved at the time and has possibly led to the perceptions that have arisen.

"The State – Federal issues are different. In that case the NSW Division is a completely separate legal entity to that of the federal body. They have distinctly and legally different accounting and responsibilities. The problem there is, 'on what grounds can they be made into one entity?' This is another saga. How are you placed for time?"

The Cumberland Group has always been fiercely politically and financially viable and independent. When the Division was restructured in 1992, I can verify as a member at the time, that the Group

Committee was intrigued to receive a cheque from the Division to fund Group activities (probably a per capita subsidy for financial members). The cheque was returned with thanks.

The Group has always complied with the existing Group Rules, including all Division Treasurer and Auditor financial and taxation requirements. Its major financial activity is its annual one-day seminar (more on Group seminars later), involving up to 350 registrants, which requires immediate access to existing Group funds for substantial deposits during the year as planning proceeds. To require an approach to a higher authority in order to justify each expenditure as it occurs would, I believe, complicate the process and destroy initiative and enterprise, given the Group's culture and background.

It has been suggested that the Group is not legally responsible for its own finances. Although the possibility of the Group incurring liabilities is considered highly unlikely, the Group Committee has indicated that it is prepared to incorporate in order to overcome these objections.

Understandably, then, there is a perception amongst group (and not only Cumberland) members that the attitude of the Division to the Groups is similar to the attitude of ISA to ISNSW and that what is proposed is really a restructure of Division and Group relationships, ostensibly involving money but really about power and control.

An unfortunate side effect of all of this has been a questioning of the wisdom of the Group's formal affiliation with the Division, carried by that narrow margin in 1985.

CHAPTER 5. 1986 – 1998.

It is now appropriate to continue that résumé (commenced in Chapter 3) of office-bearers and financial members during the remaining period for which the information is available, namely 1986 to 1991:

Financial Members (36), 16th July, 1986: W. Backhouse, R. Beeston, C. Blanchard, J. Brock, G. Caddey, K. Cadogan, B. Cawthorne, I. Cousin, K. Crispo, R. Cumming, G. Falkner, P. Friedman, J. Gallagher, B. Green, D. Groundwater, B. Harrison, P. Hunter, T. Hunter, A. Keighran, D. Lorschly B. McLeod, D. More, M. Morgan, B. Moriarty, M. Nix, G. Oxley, B. Pearson, B. Rein, C. Ryan, C. Smith, P. Strudwick, J. Sunter, P. Swan, W. Timbs, G. Wren, P. Youdal,

Annual General Meeting and Financial Members (38), 18th November, 1987: P. Alver, B. Backhouse C. Blanchard, P. Boland, K. Bourke, J. Brock, K. Cadogan, R. Cambridge, B. Cawthorne(Committee), K Crispo, R. Cumming, P. Friedman, P. Gardner, E. Garvin, T. Grabara, B. Green(Committee, apparently unfinancial), B. Harrison, P. Homann, P. Hunter(re-elected Chairman), J. Junek, D. Lorschly, B. McLeod, D. More, M. Morgan, B. Moriarty, J. Naughton, M. Nix, P. North(Committee), G. Oxley(Committee, apparently unfinancial) B. Pearson, B. Rein, C. Ryan, P. Strudwick, J. Sunter P. Swan(re-elected Secretary), W. Taylor, B. Timbs, D. Timbs(Committee), G. Wren(re-elected Treasurer), P. Youdal.

Annual General Meeting and Financial Members (35), 27th November, 1988: J. Abbott, P. Alver, B. Backhouse(Committee) C. Blanchard, P. Boland, J. Brock(Committee), G. Caddey, K. Cadogan, S. Carr, B. Cawthorne, R. Cumming, E. Garvin(Committee), D. Groundwater, A. Halmarick, P. Homann, P. Hunter(retiring Chairman), J. Junek, D. Kimber, D. Lorschly, R. Lowe(Committee), A. Martin, D. McArthur, B. McLeod, M. Morgan, J. Naughton, C. Newton, M. Nix, P. North(new Chairman), G. Oxley(Committee, apparently unfinancial), P. Strudwick, J. Sunter, P. Swan(re-elected Secretary), B. Timbs, D. Timbs, G. Turnidge, G. Wren(re-elected Treasurer).

Financial Members (54), 15th September, 1989: J. Abbott, P. Alver, Apps. K, A Atkins, G. Atkins, B. Backhouse, T. Banks, G. Berthold, C. Blanchard, J. Brock, K. Burke, G. Caddey, K. Cadogan, S. Carr, B. Cawthorne, T. Clarke, I. Cousin, R. Cumming, L. Forbes, M. Freeburn, P. Gardner, E. Garvin, T. Grabara, D. Groundwater, P Harrison, P. Homann, B. Ivin, G. Junek, J. Junek, G. Lenton, D. Lorschly, R. Lowe, R. Martin, B. McKinlay, B. McLeod, G. Monahan, M. Morgan, P. North, G. Oxley, M. Parkinson, T. Rogerson, C. Ryan, P. Sheedy, P. Strudwick, R. Strutt, S. Sudgen, J. Sunter, P. Swan, W. Thomas, B. Timbs, D. Timbs, G. Wren, P. Youdale, R. Young.

Annual General Meeting 27th November, 1989: All existing office-bearers were re-elected, namely: Chairman Phil North; Secretary Paul Swan; Treasurer Gordon Wren; Committee Members Bill Backhouse, John Brock, Ed Garvin, Greg Oxley, Roy Lowe; new Committee Member Matthew Freeburn.

Financial Members during 1990 (38 maximum), : J. Abbott, S. Abbott, P. Alver, B. Backhouse, P. Bolan, J. Bowden, J. Brock, K. Burke, G. Caddey, K. Cadogan, B. Cawthorne, G. Chadwick, I. Cousin, L. Forbes, M. Freeburn, E. Garvin, P Harrison, M. Hastings, P. Homann, G. Junek, J. Junek, M. Lockley, D. Lorschly, R. Lowe, R. Martin, B. McKinlay, M. Morgan, P. North, B.Rein, P. Sheedy, S. Sudgen, J. Sunter, P. Swan, B. Timbs, D. Timbs, C. Tisdell, T. Todarello, G. Wren,.

Annual General Meeting 17th November, 1990: new Chairman Ed Garvin; new Secretary Greg Oxley; re-elected Treasurer Gordon Wren; Committee Members Matthew Freeburn, Phil North (retiring Chairman), Roy Lowe, Paul Swan (retiring Secretary).

This Committee was responsible for running the first Cumberland Group seminar on 28th June, 1991, with a theme of: "Staged Stratas and Community Titles ... 12 months on". 220 registrants attended. The seminar was highly successful and was followed by the Group's first 'End of Financial Year' Dinner. (See Appendix G)

No Group history would be complete without a special mention of these events. These one-day seminars and following dinners are held annually in June at the Sunnybrook Travelodge Convention Centre, Hume Highway, Warwick Farm.

They are the biggest event in the Group calendar. All have been professionally and financially successful and the attendances have all been close to the maximum number projected and spaces available.

At the end of 1991 Ed Garvin recruited me onto the Group Committee. I found out recently that he was keen to see public sector surveyors represented on the Committee. In typical style he simply looked at me at the end of a meeting and said: "Keith, you should be on Committee." Considering the amount of effort I knew he contributed to the Group, it was difficult to refuse. The second Group annual seminar was held on 26th June, 1992 (See Appendix H). It was organised by a Group Committee comprising: Chairman Ed Garvin; Secretary Greg Oxley; Treasurer Roy Lowe; Committee Members: Keith Cadogan, Ron Cumming, Matthew Freeburn, Bob Hanna, Gerard Junek, Michael Parkinson. 130 registrants attended, and its theme was: "Land Development in 1992".

On 2nd September, 1992, the Group hosted the President of the Division, Phil Atkinson, at its regular General Meeting at the Parramatta Club. At the time there were problems involving the Division and the then Trade Practices Commission. The ramifications from these problems continue to be matters for consideration by the Division. For whatever reason, which was not recorded, the President advised the Group to no longer keep minutes and records. From this time on, no such records have been made or kept by the Group, which is bad news for any future researchers. The only written records are Group reports in Azimuth, and seminar flyers, programs and presenters' papers published by the Group.

The third Group annual seminar was held on 25th June, 1993 (See Appendix I). It was organised by a Group Committee comprising: Chairman Greg Oxley; Secretary Ron Cumming; Treasurer Roy Lowe; Committee Members: Keith Cadogan, Matthew Freeburn, Bob Hanna, Gerard Junek, Brian McKinlay, Michael Parkinson. Its theme was: "Development in 1993".

The next two Group annual seminars were held on 24th June, 1994 and 23rd June, 1995 (See Appendixes J & K). They were organised by a Group Committee comprising: Chairman John Brock, Secretary Ron Cumming; Treasurer Roy Lowe; Committee Members: Keith Cadogan, Matthew Freeburn, Bob Hanna, Gerard Junek, Brian McKinlay, Greg Oxley; Michael Parkinson. Their themes were: "Development in 1994 'The Burning Issues' "and "Development in 1995 'Toads, Trains, Townhouses & Titles' ".

The sixth and seventh Group annual seminars were held on 21st June, 1996 and 20th June, 1997 (See Appendixes L & M). They were organised by a Group Committee comprising: Chairman Roy Lowe; Secretary Michael Parkinson; Treasurer Bob Hanna; Committee Members: John Brock, Keith Cadogan, Ron Cumming, Gerard Junek, Brian McKinlay, Greg Oxley, Barry Yardley. More than 300 registrants attended both seminars and their themes were (predictively): "Development in 1996/1997".

The most recent Group (eighth) annual seminar was held on 26th June, 1998 (See Appendix N). It was organised by a Group Committee comprising: Chairman Roy Lowe; Secretary Michael Parkinson; Treasurer Gerard Junek; Committee Members: John Brock, Keith Cadogan, Ron Cumming, Bob Hanna, Brian McKinlay, Greg Oxley, Barry Yardley. More than 350 registrants attended this seminar and its title was (again predictively): "1998 Development Seminar".

A current list of Group financial members (as at 26th August, 1998) is as follows: Greg Atkins (G. J. Atkins & Assoc.); Paul Barry (Bowdens); Grahame Berthold (Dept Public Works); Ern Britten (E. J. Britten & Assoc.); John Brock (Rose Consulting); Martin Burke (Sydney Water); Graham Caddey (Caddey & Assoc.); John Caddey (Caddey & Assoc.); Keith Cadogan (Retired); Stephen Carr (Bowdens); John Cassidy (Dept of Housing); Mark Castelletti (E. J. Garvin & Company); Geoff Chadwick (Chadwick Cheng & Assoc.); Simon Cheng (Chadwick Cheng & Assoc.); Terry Clark (RTA); Les Cook (Sydney Water); Ian Cousin (Integral Energy); Patrick Cram (E. J. Garvin & Company); Ron Cumming (Donovans); Alan Cuthbert (A. J. Cuthbert & Assoc.); Phil Dixon (Dept Public Works); Andrew Edwards (McKinlay Morgan & Assoc.); Ted Firth (Ryan Firth & Assoc.); Bob Flegg (R. A. Flegg & Assoc.); Colin Foulds (John N. Brown, Lenton & Co Pty Ltd); Peter French (Bowdens); Ed Garvin (E. J. Garvin & Company); John Gillies (RTA-Geosystems Section, Parramatta); Steve Gollan (S. Gollan Surveyor); Mark Gordan (RTA); Brian Gowen (Brian Gowen Surveying); Thierry Grabara (T. Grabara & Assoc.); Ken Graf (Residential Land Projects); Barrie Green (Barrie Green & Assoc.); Bob Hanna (DPWS); Murray Hastings (BLH Consulting); Ian Iredale (Iredale & Assoc.); Kent Jones (Craig & Rhodes); Gerard Junek (Junek & Junek); Ray Kao (Asher McNeil Niall); Ian Lackenby (Lean Lackenby & Hayward); Tony Lei (Lovegrove Oxley); Richard Lemon (LandInfo Pty Ltd); Geoff Lenton (John N. Brown, Lenton & Co Pty Ltd); David Lorschy (RTA-City); Roy Lowe (Donovans); Damien Maguire (Michael Lockley & Assoc.); Eric Maronese (Parramatta Council); Jason Martin; Don Martin (AWT Survey); Alf Martin (R. W. Martin & Assoc.); Ken McCrow (McLeod & McCrow); Glenn McFall (Peter & Matthew Freeburn); Brian McKinlay (McKinlay Morgan & Assoc.); Barry McLeod (McLeod & McCrow); Michael Meyer (McKinlay Morgan & Assoc.); Geoff Meyer (G. B. Meyer & Assoc Surveyors); Alis Migus (AWT); Michael Morgan (Ryan Firth & Assoc.); Chris Moyce (Michael Lockley & Assoc.); Richard Muldoon (Asher McNeil Niall); James Niall (Asher McNeil Niall); David Norris (LTO); Greg Oxley (Lovegrove Oxley); Michael Parkinson (Donovans); Bob Pascoe (Lovegrove Oxley); Helen Pollock (RTA- Parramatta); Bob Rankins (RTA- Parramatta); Matthew Riddell ((BLH Consulting); Terry Rogerson (Geomatics Section Dept Public Works); Tony Rood (Asher McNeil Niall); Michael Rutledge (RTA); Chris Ryan (More & Ryan Surveys); Peter Sheedy ; Victor Smith; Frank Smith (AWT); Daniel Schmultz (Schmultz & Company); Brad Spice (Lovegrove Oxley); Alan Turner (Alan G Turner & Assoc.); Graham Wilson (Mudge Wilson); Barry Yardley (SRA).

This list indicates that the Cumberland Group is alive and well and continues to look after the interests (including CPD requirements) of its membership. Its Committee meets monthly and it

holds General Meetings every two months. For example, it conducted a special seminar/meeting last month (12th August, 1998) on "Integrated Assessments Explained". Sixty-five members and visitors attended at the (historically appropriate) Parramatta Masonic Club.

I have always admired the straightforward, democratic, no-nonsense, practical, non-bureaucratic, and informal manner in which the Group operates. This is in sharp contrast to so many other organisations with which I have been associated.

The Cumberland Group continues to maintain 'a reluctant relationship' with the Institution of Surveyors New South Wales Incorporated.

APPENDICES

- A. Desperately Seeking Data about Wal Ayling.
- B. 1967 Group telephone list.
- C. Typical Group Letterhead, (1978).
- D. Formal Affiliation proposal, 30th August, 1985.
- E. Extract of Group Minutes of Annual General Meeting of 13th November, 1985 (affiliation vote).
- F. Division Letter dated 13th December, 1985, accepting affiliation.
- G. Group seminar invitation 28th June, 1991.
- H. Group seminar invitation 26th June, 1992.
- I. Group seminar invitation 25th June, 1993.
- J. Group seminar invitation 24th June, 1994.
- K. Group seminar invitation 23th June, 1995.
- L. Group seminar invitation 21th June, 1996.
- M. Group seminar program 20th June, 1997.
- N. Group seminar program 26th June, 1998.

APPENDIX A.

DESPERATELY SEEKING DATA ABOUT WAL AYLING

To the best of my knowledge, I never met him, although his name and work are very familiar to me from using his survey plans, and I know at least three surveyors who were his pupils.

As a co-founder of the Group, his image, life and work are obvious inclusions in this history.

To this end, I first of all consulted my fellow members of the Group Committee, where Chairman Roy Lowe informed me that Wal Ayling had died approximately one month before the Group's 1997 annual end-of-financial-year seminar.

I next consulted Heather Phillips at ISNSW. Wal Ayling's membership index card gave me his full name, his date of birth and the date he joined.

Significantly, there was no date of death. Nevertheless, I searched unsuccessfully through all copies of Azimuth for 1997 and 1998, looking for his obituary.

Next I returned to the Group Committee, who advised me to seek out Brian Gowen, who, I was told, had bought Wal Ayling's practice from him. Brian Gowen is a Group member and well known to me. He informed me that he had already prepared an obituary and had it published. He readily offered to send me a copy, but despite my following him up on not less than six different occasions over a number of months, it would appear that he cannot find it. When I mentioned my unsuccessful search of Azimuth, he informed me that he had sent it to ACS.

I thereupon sought Heather Phillip's aid again, and she approached the staff of both ACS and ISA (in Canberra), but apparently they were unable to locate an obituary.

In an attempt to gain more information about his death, family, heirs and assigns, at the State Library I unsuccessfully searched Death Notices published over a period of six months period in the Sydney Morning Herald. This is quite laborious, given the size of some editions (especially Saturday's) and the fact that there is no index of Death Notices.

This whole process so far has greatly delayed the completion of this history, and I am already well past my deadline. Further possibilities include applying for a Death Certificate and/or telephoning the 46 Aylings listed in the current telephone directory, but neither of these actions will lead directly to the kind of obituary information that I need, and which (I am told) already exists.

It is hard to believe that, together with other obvious gaps in available data, the missing information, namely the image, life and work of Wal Ayling, will not be forthcoming when this history becomes widely available amongst other surveyors. When it comes to light, I look forward to filling this gap in the Group's history.

APPENDIX B.

1967 Group telephone list.

NAME	ADDRESS
T. Austin	320 Pacific Highway, Lane Cove
W. Ayling	16 George Street, Parramatta
Keith Austin	406 Chapel Road, Bankstown
K. Bourke	c/o Blacktown Municipal Council
B. O'Rourke	c/o Blacktown Municipal Council
J. Blair	c/o Blacktown Municipal Council
J. Kerr	c/o Blacktown Municipal Council
B. McCloskey	c/o Blacktown Municipal Council
E. Britten	24 Ware Street, Fairfield
W. Timbs	24 Ware Street, Fairfield
W. Buxton	171 Victoria Road, Drummoyne
P. Byrnes	c/o K. Austin 406 Chapel Road, Bankstown
V. Clements	71 George Street, Parramatta
A. Campton	40 Lennox Street, Old Toongabbie (c/o Stocks & Holdings)
B. A. Curtis	4 Castlereagh Street, Sydney
C. Dark	4 Castlereagh Street, Sydney
R. Degotardi	c/o J. Hagan & Associates Consulting
N. Hayes	Engineers, 425 Victoria Avenue, Chatswood
V. Exley	48 Macquarie Street, Parramatta
G. Fuller	32 President Avenue, Caringah
D. J. Finney	33 Lawndale Avenue, North Rocks
F. H. Freeguard	16 Maher Street, Hurstville
P. Freeburn	344 High Street, Penrith
K. Hamilton	90 Hilda Street, Blaxland
W. G. Hunt	24 Hunter Street, Parramatta
J. Massey	24 Hunter Street, Parramatta
K. Hainge	c/o Busby 48 Macquarie Street, Parramatta
B. Homann	80 Northumberland Street, Liverpool
E. Hunter	2 Winslow Street, Milsons Point
K. Jones	c/o Craig & Rhodes Langston Place, Epping
R. Scott	c/o Craig & Rhodes Langston Place, Epping
J. W. Keown	147A King Street, Sydney
D. More	147A King Street, Sydney
R. Smith	147A King Street, Sydney
P. Lean	109 Bigge Street, Liverpool
I. Lackenby	109 Bigge Street, Liverpool
R. Lovegrove	43 Prince Charles Road, French's Forest
P. M. McCartney	Round Corner Dural
K. McCrow	204 & 228 Merrylands Road, Merrylands
B. McLeod	204 & 228 Merrylands Road, Merrylands
J. P. O'Keefe	Cnr George & Marsden Streets, Parramatta

E. Maronese	Cnr George & Marsden Streets, Parramatta
J. Menzies	384 Church Street, Parramatta
R. Menzies	384 Church Street, Parramatta
G. Moore	Wallis & Moore 147 Macquarie Street Sydney
G. Murray	121 George Street, Liverpool
K. Morrow	22 Cooper Street, Strathfield
K. A. Pothan	85 Walker Street, North Sydney
D. Rich	63-65 Burwood Road, Burwood
R. Sonter	c/o Fairfield Municipal Council
N. Smith	29 Macquarie Street, Parramatta
W. Taylor	3 Kelvin Street, Ashbury
G. Turnidge	32 York Street, Sydney
P. Price	32 York Street, Sydney
P. Holland	100 Rowe Street, Eastwood

APPENDIX C

INSTITUTION OF SURVEYORS

CUMBERLAND GROUP

CHAIRMAN : J. Sunter

SECRETARY : A. Cawthorne

11 Apps Avenue,
TURRAMURRA, N.S.W. 2074
28th June, 1978.

Dear Member,

At the General Meeting held on 21st June, 1978, you signified your intention of attending the meeting to be held at the Scientific Branch C.I.B. of the N.S.W. Police Department on 20/9/78. You also indicated that your wife would accompany you.

I have spoken to Det. Sgt. Snowden with a view to increasing the allowable number of visitors. Sgt. Snowden regrets it is not possible to increase to more than 40 as his premises will not accommodate more than that number.

On a show of hands on 21/6/78, 19 members indicated they would attend with their wives, and one member without wife - a total of 39.

It is thought that some of the ladies may not wish to attend the meeting but would be interested only in attending the smorgasbord supper at the Mandarin Club. If this is the case, it will leave a few vacancies for other members who were not present at the June meeting, but who would undoubtedly wish to attend on 20/9/78.

Before I undertake any advance publicity in respect of the September meeting it will be appreciated if you will kindly complete the enclosed pro forma and return it to me not later than 10th July, 1978. This will enable me to finalise arrangements with Sgt. Snowden and with the Mandarin Club in regard to catering.

Please help the P.B Secretary in his efforts to avoid a SNAFU !

Yours sincerely,

(Signed)

A.Cawthorne,

Honorary Secretary

Encl.

APPENDIX D

11 Apps Avenue,
TURRAMARRA NSW 2074

30th August, 1985

Mr. W. Backhouse,
Chairman,
Cumberland Group of Surveyors,
c/o Collin C. Donges & Associates Pty Ltd.,
P.O. Box 219,
DURAL N.S.W. 2158

Dear Sir,

Two letters published in the August issue of "Azimuth" have prompted me to write to you in relation to affiliation of the Cumberland Group with the N.S.W. Division of the Institution of Surveyors, Australia.

To me, the letters appear to be a plea for solidarity and the presenting of a united and cohesive body of professional surveyors to the public and government.

Since its formation the Cumberland Group has been an autonomous body of surveyors meeting in good fellowship to discuss matters of interest to the profession. This has been a successful format and has contributed much to the profession of surveying. However, the time has now arrived where I believe that the Cumberland Group should be affiliated with the NSW Division of the Institution and propose that this matter should be discussed firstly at a committee meeting of the group, and thereafter the results of that discussion be presented to the members of the group at the Annual General Meeting to be held on 13th November, 1985. After a suitable discussion period, the members should then be asked to vote on the following proposition:

"That the Cumberland Group of Surveyors make a formal application to the NSW Division of the Institution of Surveyors, Australia, for affiliation with the Division on the same terms and conditions as at present apply to the other Groups presently meeting and operating within New South Wales."

I believe that such an affiliation will be of benefit to the Institution and the Cumberland Group, and thereby to the profession of surveying as a whole.

Yours faithfully,

(Signed)

A. Cawthorne.

APPENDIX E

Extracts from the Cumberland Group Annual General Meeting held at the Masonic Club, Parramatta, on 13th November, 1985:

The Chairman (W. Backhouse) opened the meeting at 8.25pm.

Apologies were received from Messrs Blume, Lackenby, Shepherd, Nix, Fuller, and Green. ...

Treasurer's Report: ...July Room Fees: \$50 ...Subs 7 @ \$5 ...Current Balance: \$89.86 Financial Members 29...

General Business: The Chairman requested Bert Cawthorne to address the meeting, as follows: Brief details of Applications for Recognition by NSW Division of the Institution of Surveyors.

13th December, 1963. Group formed to be known as the Cumberland Group. Chairman Wal Ayling, Secretary Vernon Clements. It was agreed that the Group should not be autonomous nor make direct approach to anybody without the concurrence of the NSW Division. The NSW Council was asked to grant recognition to the Group.

18th March, 1963. NSW Council acknowledged that it would be pleased to co-operate with the Group.

13th November, 1963. Group requested the Council for recognition as an "Institution Activity". This was apparently not accepted by the Council.

20th November, 1970. Application submitted to NSW Division for recognition as a "Co-operating Association".

16th December, 1970. Application rejected by NSW Division on the grounds that "the Group has not indicated any particular identity."

24th February, 1971. Application re-submitted to NSW Division.

12th March, 1971. NSW Division again reject the application and suggest that the Group make application for recognition as a sub-division.

Subsequently the matter was discussed on several occasions and finally, on 14th March, 1973, it was resolved that the matter of recognition by the NSW Division be left in abeyance.

Despite the lack of recognition by the NSW Division the Group continued to meet and to discuss matters of interest and concern to the profession, and to forward their views to the Division.

One of the most important decisions of the Group was to propose and bring into effect the Association of Consulting Surveyors.

Throughout the whole of its existence the Group has consistently raised and discussed matters affecting the profession and has always reported on its activities to the NSW Division, thus

exemplifying its intention of remaining part of the Institution despite the lack of formal recognition by the NSW Division.

Two letters published recently in *Azimuth* appeared to me to be a plea for all members of the profession to work together for the good of the profession and to present a united, strong and solid body of opinion to Government Departments at all levels, and to the general public. We cannot do this until such time as all members of the profession, both students and qualified surveyors, become members of the Institution of Surveyors, and until such time as the Cumberland Group becomes officially recognised by the NSW Division Incorporated.

By applying for and obtaining affiliation with the NSW Division Incorporated, I believe the following benefits will accrue to the Group:

1. An official voice in all matters pertaining to the affairs of the Division.
2. A closer liaison with the Division in its decision-making processes.
3. Use of the Division's premises for meetings and discussions by arrangements and as required.
4. The holding of Division meetings at Parramatta by agreement.
5. The support of the Division in all undertakings approved of and relating to the good of the profession.
6. A united and cohesive body of professional surveyors.

I now formally submit the following proposition for discussion and resolution by vote of the members present at this meeting:

"That the Cumberland Group of Surveyors make a formal application to the Committee of the Institution of Surveyors, New South Wales Incorporated, for affiliation with the Institution on the same terms and conditions as at present apply to the other Groups presently meeting and operating within New South Wales."

... motion ... was seconded by D. Timbs.

W. Timbs as an inaugural member of Cumberland Group pointed out the benefits of a forum in the dissemination of information. We stand to lose our independence at what gain?

J. Sunter addressed the meeting for the case against affiliation. The first meeting discussed "shady" practise in the area. Emphasis has been on the private practitioner and keeping in touch. We are a comfortable mix of degree and articles, employer and employee with open meetings which aid keeping abreast. A.C.S. was born from our Group. Letters from Messrs Green, Rein and Barrie were sighted as supporting us. The critical points are:

- (a) Can we do more for the Institution in our present form? Will affiliation gag debate?
- (b) Will we be a further drain on the Institution's funds?

(c) Will the free flow of ideas cease? Therefore recognize us but do not formalize us.

J. Brock sees no alteration except for an increased membership due to a newly found direct say.

The Chairman called upon T. Jackson (Executive Officer) to address the meeting.

Tom assured the meeting that we would remain independent. Once each year, however, the President would visit a meeting. Tom sees the Group growing from weak to respected. We may have to hold an A.G.M. for the Institution. We would not be bound by area. We would receive a per capita subsidy of \$4.50 (Financial Members). The Institution would be responsible for our financial status. We must have two general meetings and one A.G.M. per year. A Treasurer's report could be called for. We would not be obliged to furnish minutes.

Some discussion followed. It appeared that under present rules we would be obliged to have one member on the Institution Committee thereby increasing its size.

Barry McLeod admitted his 50/50 attitude like many others. Perhaps our best reason to do anything is to stay a rejected yet popular group. D. Lorchy supported this view sighting the Articles of Association as allowing for various supporting Groups. We would inherit the ties of a company. Colin Blanchard suggested that we must ignore the trivia and look to the future. Phil Hunter saw representation on Committee as important.

Mr. Cawthorne's motion was put again to the meeting and carried ten to eight.

Election of office bearers then took place with Mr. Jackson in the chair:

Position	Nominee	Proposer	Secunder	Result
Chairman	W. Backhouse	C. Ryan	J. Sunter	Carried
Secretary	P. Strudwick	A. Cawthorne	P. Youdale	Carried
Treasurer	G. Wren	J. Sunter	A. Keighran	Carried
Committee	C. Ryan			
	D. Timbs			
	J. Sunter			
	P. Youdal			
	B. Green			
	P. Hunter			Carried ...

APPENDIX F

Letter from The Institution of Surveyors NSW Incorporated dated 13th December, 1985 notifying formal acceptance of affiliation of the Group by the Division.

Mr. W Backhouse
Chairman
Cumberland Group
38 Selkirk Street
WINSTON HILLS

Dear Sir,

The Committee of the Institution considered the request of the Cumberland Group for [affiliation] with the Institution at its meeting on Friday, 6th December, 1985.

The following two motions were carried:

"In response to the request from the Cumberland Group the Committee approved of an association to be known as "Institution of Surveyors, Cumberland Group" as a cooperating association within the Institution."

and further

"Capitation fees will be paid to the Cumberland Group on a financial member of the Group basis and not on a geographical basis ."

The Committee decided to adopt the cooperating association basis due to difficulties with our articles and the difficulties involved with determining geographic boundaries. I personally consider the differences immaterial from the discussions I heard at your meeting.

If you have any queries, please do not hesitate to contact me.

Yours faithfully,

(Signed)

T. C. JACKSON
Executive Officer

APPENDIX G

THE
CUMBERLAND
GROUP OF SURVEYORS

INVITES YOU TO ATTEND

**"STAGED STRATAS
& COMMUNITY TITLES
.... 12 MONTHS ON"**

A SEMINAR TO LOOK AT THE PRACTICALITIES, LEGAL
AND OTHER ASPECTS OF THE COMMUNITY TITLES ACT
AND THE STAGED STRATA ACT

VENUE: *The Sunnybrook Travelodge Convention Centre
Hume Highway, Warwick Farm*

DATE: *Friday 28 June 1991 Starting at 8:30 A.M.*

AGENDA: *Includes speakers from the Land Titles Office,
Dept of Planning, Lawyers, Property Developers,
Surveyors, Strata Consultants and Service Authorities*

**THE SEMINAR WILL BE FOLLOWED BY AN
END OF FINANCIAL YEAR DINNER COMMENCING AT 7:00 P.M.**

COST: *Seminar \$80 Dinner \$45 each*

MAX NUMBERS 150, BOOK EARLY TO AVOID DISAPPOINTMENT

*Please detach the following and return to The Treasurer, Cumberland Group of Surveyors
PO Box 384 Parramatta or DX8215 Parramatta*

NAME(S): _____ **PHONE:** _____

ORGANISATION: _____ **FAX:** _____

POSTAL ADDRESS OR DX: _____

PLEASE FIND ENCLOSED CHEQUE/MONEY ORDER FOR \$ _____

_____ **PLACES AT THE SEMINAR AT \$** _____

AND _____ **PLACES AT THE DINNER AT \$** _____

ENQUIRIES

ED GARVIN PH 879 7263

GREG OXLEY PH 831 4167

ROY LOWE PH 633 9211

FAX 891 2806

APPENDIX H

INSTITUTION OF SURVEYORS CUMBERLAND GROUP

Invites you to attend a seminar on aspects affecting

LAND DEVELOPMENT IN 1992

Topics include:

Impact of SEPP 25
Amendments to the L.G.A.
Draft Manual for Sec 94 contribution
On site detention systems
Soil & water management plans
Innovative Housing Design

Speakers from:

AV Jennings, Council, Dept of Planning
Phillips Fox Solicitors
Department of Planning
Upper Parramatta River Catchment
Soil Conservation & Water Resources
Department of Housing

WHEN: Friday 26th June 1992

TIME: 8:45 - 5:15pm

WHERE: Sunnybrook Travelodge, Hume Highway, Warwick Farm

COST: \$85.00 includes lunch, morning & afternoon teas.

To be followed by our Annual End of Financial Year Dinner to be held at the Travelodge. Cost \$45.00

Dinner Commences 7:30 pm

Please make cheque payable to "Cumberland Group of Surveyors"

Send reply to: The Treasurer - Cumberland Group

c/- P.O. Box 209 Parramatta 2124, DX 28353 Parramatta

Tear off below dotted line

Please register the following at \$85 each for the land development seminar on Friday 26th June.

Name:

Organisation:

DX:or Address:

Phone:

Number of persons attending Seminar (\$85.00)

Number of persons attending Dinner (\$45.00)

List other names attending

.....

.....

.....

Cheque enclosed for the amount of \$

Enquiries ph: Ron Cumming (897-3355), Roy Lowe (633-9211), or Grcg Oxley (831-4167).

APPENDIX I

INSTITUTION OF SURVEYORS CUMBERLAND GROUP

Invites you to our seminar on aspects affecting

DEVELOPMENT IN 1993

Topics include:

- Impact of SEPP 25 & proposed revisions
- Torrens vs. Strata vs. Community Title
- Integrated Housing, AMCORD
- Building Code of Australia
- Effect of Legislation on development

Speakers from:

- Local Councils
- Department of Planning
- Greenstreet Secretariat
- Trevor Howarth, Consultant
- Developers

When: 9:00AM to 5:15PM
Date: Friday 25th of June, 1993
Where: The Sunnybrook Travelodge, Hume Highway WARWICK FARM
Cost: \$95 (Non-members) \$85 (Institution Members)
(Cost includes lunch, morning and afternoon teas)

The Seminar will be followed by our "Annual End of Financial Year Dinner", held at the Travelodge. Cost \$45 each. (wives and partners welcome.)

RSVP June 18th 1993

Please make cheques payable to "Cumberland Group of Surveyors"
Send reply to: **The Secretary, Cumberland Group of Surveyors**
c/- PO Box 209 Parramatta or **DX28353 Parramatta**

CPD Points are assessed as 6 points

APPENDIX J

INSTITUTION OF SURVEYORS CUMBERLAND GROUP

Invites you to our seminar on:

DEVELOPMENT IN 1994 *'THE BURNING ISSUES'*

Topics include:

- Impact of 1994 bushfires on planning & development
- Preferred quality system for the Water Board
- Dual (or duel) occupancy - update
- Medium/high density - rising into the future
- EPA requirements on development - the cost
- On-site detention requirements and the problems

Speakers from:

- Bushfire Council
- Department of Planning
- Water Board
- Developers
- Local Government
- Consultants

When: 9:00am to 5:30pm

Date: Friday 1st July, 1994

Where: The Sunnybrook Travelodge, Hume Highway, WARWICK FARM

Cost: \$105 (Non-members) \$90 (Institution members)
(Cost includes lunch, morning and afternoon teas)

The Seminar will be followed by our "Annual End of Financial Year Dinner", held at the Travelodge. Cost \$45 per person (wives and partners welcome).
Note: Special rates available on overnight accommodation (additional cost).

RSVP June 24th, 1994

Please make cheques payable to "Cumberland Group of Surveyors".

Send reply to: **The Secretary, Cumberland Group of Surveyors**

c/- PO Box 209 PARRAMATTA or DX28353 Parramatta

CPD Points are assessed as 6 points

✂

Please register the following for the Development in 1994 Seminar on Friday 1st July 1994.

Name(s)..... Occupation:

Organisation:..... Phone: (.....) Fax : (.....)

DX (or address)..... Suburb/Town:

No. of persons attending seminar..... @ \$..... Total \$.....

No. of persons attending dinner @ \$45 Total \$..... Cheque enclosed for \$.....

Enquires phone: Ron Cumming (897-3355) Roy Lowe (633-9211) Greg Oxley (831-4167)

APPENDIX K

INSTITUTION OF SURVEYORS CUMBERLAND GROUP

Invites you to our next seminar on:

DEVELOPMENT IN 1995 'TOADS, TRAINS, TOWNHOUSES & TITLES'

Topics include:

- Fauna Protection Act - Effects on Development
- Can a toad stop your development?
- Urban Transport Strategy for future development in NSW
- Where the new development areas are targeted
- Update on Dual occupancy - Is it doomed?
- Medium/high density - next stage in Urban Consolidation?
- Community Titles versus Strata Title - which one is best?

Speakers from:

- National Parks & Wildlife
- Environmental Consultants
- Environment Protection Agency
- SRA and RTA
- Developers
- Local Government
- Land Titles Office

NOTE: THERE WILL ALSO BE TECHNICAL & TRADE EXHIBITS ON DISPLAY

When: 9:00 am to 5:15 pm
Date: Friday 23rd June, 1995
Where: The Sunnybrook Travelodge, Hume Highway, WARWICK FARM
Cost: \$115 (Non-members) \$95 (Institution members)
(Cost includes lunch, morning and afternoon teas and 'happy hour')

The Seminar will be followed by our "Annual End of Financial Year Dinner", This years dinner will feature a guest speaker, Dr Boyo Ockinga, the world renowned archaeologist and ancient historian from the Macquarie University who will give a colourful illustrated presentation on 'The latest finds in Ancient Egypt'. Cost only \$45 per person includes 3 course meal and music (wives and partners welcome). Note: Special rates available on overnight accommodation (please phone for details).

RSVP June 16th, 1995

Please make cheques payable to "Cumberland Group of Surveyors".
Send reply to: The Secretary, Cumberland Group of Surveyors
c - 201/30 Cowper Street PARRAMATTA or DX28325 Parramatta

CPD Points are assessed as 6 points
This seminar has been structured to comply with the requirements of the Training Guarantee Act

Please register the following for the Development in 1995 Seminar on Friday 16th June 1995.

Name(s) Occupation

Organisation: Phone () Fax : (.....)

DX (or address) Suburb/Town.

No. of persons attending seminar : @ \$ Total \$.....

No. of persons attending dinner @ \$45 Total \$..... Cheque enclosed for \$.....

Enquires phone John Brock (671-3800) Roy Lowe (633-9211) Greg Oxley (831-4167)

APPENDIX L

INSTITUTION OF SURVEYORS CUMBERLAND GROUP

Invites you to our next highly informative seminar on:

1996 DEVELOPMENT SEMINAR "Land Law, Subdivisions & Appeals"

Topics include:

- New legislation affecting development
- Update on the repeal of the dual occ legislation
- Changes to Part XII Local Government Act
- Changes to E P & A Act
- How to be an expert witness
- Recent decisions of The Land & Environment Court
- Supreme Court versus The Land & Environment Court
- Professional Certification of design plans for development
- Electronic lodgement of survey plans to Land Titles Office
- Property Legislation Amendment (Easements) Act 1995
- Professional Standards Act

Speakers from:

- UDIA
- Environmental Consultants
- Environmental Solicitors
- Land & Environment Court
- The Legal Profession
- Developers
- Local Government
- Land Titles Office - Legal Branch
- Land Titles Office - Survey Branch
- Private practice

NOTE. THERE WILL ALSO BE TECHNICAL & TRADE EXHIBITS ON DISPLAY

When: 8:45 AM to 5:15 PM (Registration & coffee from 8:30 AM)
Date: Friday 21st June 1996
Where: The Sunnybrook Travelodge, Hume Highway, WARWICK FARM
Cost: \$125 (Non-members) \$105 (Institution members)
(Cost includes lunch, morning and afternoon teas and 'happy hour')

CPD Points are assessed as 6 points (including 2 cadastral) for Seminar & 2 points for dinner talk

The Seminar will be followed by our "Annual End of Financial Year Dinner" featuring guest speakers, Alan & Delma Cavanagh, who will give a colourful illustrated presentation on their recent trip to Egypt to survey ancient tombs. Cost only \$55 per person (\$45 members & their partners) includes 3 course meal, drinks and music (wives and partners welcome).

Note. Special rates available on overnight accommodation (please phone for details).

RSVP June 14th 1996

Please make cheques payable to "Cumberland Group of Surveyors" and send reply to:
The Secretary, Cumberland Group of Surveyors c/- 201/30 Cowper Street PARRAMATTA or DX28325 Parramatta

Please register the following for the 1996 Development Seminar by Friday 14th June 1996. (One form per registrant please)

Name	Occupation
Organisation		Phone ()	Fax ()
DX (or address)		Suburb/Town	P/Code
Registration at Seminar	q \$	Sub-total \$	
No. of persons attending dinner	q \$	Sub-total \$	Cheque enclosed for \$
Enquiries phone:	Roy Lowe (633-9211)	John Brock (671-3800)	Greg Oxley (831-4167)

APPENDIX M

INSTITUTION OF SURVEYORS CUMBERLAND GROUP

proudly presents the following seminar on

1997 DEVELOPMENT SEMINAR

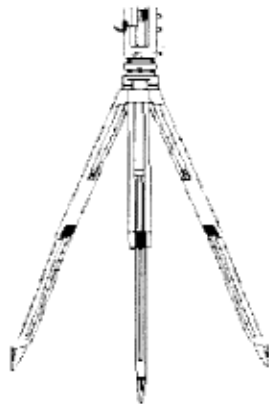

Held in the Kingfisher/Currawong/Kookaburra rooms of the Sunnybrook Travlodge
Cnr of Hume Highway and Liverpool Street, Warwick Farm.

Friday 20th of June, 1997

INSTITUTION OF SURVEYORS CUMBERLAND GROUP

Background

First formed in 1962 as a vehicle for local Surveyors to meet for fellowship and to exchange professional views, the Cumberland Group is one of the oldest such groups in New South Wales. Out of this group was also formed the Association of Consulting Surveyors (Australia) to specifically look after the needs of Consulting Surveyors in private practice.

In the early 70's under the Chairmanship of Bernie Moriarty and with Bert Cawthorne as Secretary, the Cumberland Group started organising guest speakers covering surveying related topics. Very soon the Group obtained a good reputation for organising successful and enjoyable meetings with interesting and informative speakers and this has been carried through to the seminar today.

The Cumberland Group still embodies the original aims and objectives as when it first began and meets every two months over dinner with guest speakers covering a wide range of topics from the latest legislation changes, development issues and other surveying related topics. We also hold a Ladies Night once a year with dinner and dancing at one of the local international hotels in the Parramatta area.

Our current venue for meetings is at the Parramatta Masonic Club, Parramatta.

Membership is open to all financial members of the Institution of Surveyors and guests are also most welcome. For more information please phone (02) 9633-9211.

Proceedings

Today marks the seventh annual seminar that the Cumberland Group has presented. Our aim has always been to offer value for money seminars that are both informative and enjoyable. This years seminar has again proved popular with more than 300 registrants. As always we would welcome any constructive criticism or positive comments on your impressions on today's proceedings.

Following the tradition of our previous seminars, which have presented the planning policies and how things are intended to work, the focus of today's seminar is directed towards the practicalities and what happens in the 'real world'.

After the seminar this year, the Cumberland Group is hosting the Institution of Surveyors NSW Incorporated Annual Dinner with a special guest speaker, Major Les Hiddons famous as the Bush Tucker Man giving a presentation on an early Dutch settlement in Australia 100 years before Sydney's first settlement.

We thank you for your participation today and trust that you will enjoy the proceedings and we look forward to seeing you again at our future seminars.

Committee

1997 Cumberland Group Committee:

Chairman: Roy Lowe

Secretary: Michael Parkinson

Treasurer: Bob Hanna

Greg Oxley, John Brock, Gerard Junek, Keith Cadogan, Ron Cumming, & Brian McKinlay

TIMETABLE OF EVENTS

Development Seminar held on Friday, 20th of June 1997 held at the Sunnybrook Travelodge, Warwick Farm

Time		Speaker
8.00 - 8.45	Early morning tea/coffee	Trade displays & exhibitions
8.45 - 8.55	Welcome/Housekeeping	Roy Lowe, Cumberland Group Chairman
Session 1 "New EP&A Act - Integrated Assessment"		
9.00 - 9.20	Ramifications on the Development Industry	<i>Introduced by Greg Oxley</i> Terry Goldacre, President UDIA
9.20 - 9.40	Ramifications on Local Authorities	Wayne Gersbach, Senior Development Planner Blacktown Council
9.40 - 10.00	Downside of reform	Ian Robertson, HABSA
10.00 - 10.25	Questions	
10.25 - 10.30	Presentation of Exhibitors	
10.30 - 11.00	Morning Tea	
Session 2 "Valuation/Acquisition"		
11.00 - 11.25	Acquisition for Badgery's Creek Airport, the M2 and "Just Terms"	<i>Introduced by John Brock</i> Kent Wood, Director - K D Wood & Associates P/L
11.25 - 11.50	Land Acquisition (Just Terms Compensation) - Does it mean "Just Terms" for property owners?	Col Sorrenson, Valuer - M J Davis Valuations
11.50 - 12.15	Property Management for Government Projects	John Masters, Project Land Services, State Projects DPWS
12.15 - 12.30	Questions	
12.30 - 1.30	Lunch	
Session 3 "Development Constraints-Unravelling the Web" <i>Introduced by Brian McKinnon</i>		
1.30 - 1.55	Issues relating to Urban Development - The evolution of assessment procedures	Glenn Falson, Falson & Associates
1.55 - 2.20	Issues relating to Rural Development	Ian Sinclair, Wollondilly Council
2.20 - 2.45	Determination & Assessment of Major State Projects	Chris Wilson, Co-ordinator/Senior Environ. Planner Major Development Unit, DU/AP
2.45 - 3.00	Questions	
3.00 - 3.30	Afternoon Tea	
Session 4 "Update on Development Issues"		
3.30 - 3.55	Proposed Changes to provision of electricity and update on contestability	<i>Introduced by Michael Parkinson</i> Rod O'Donoghue, Contestability & Accreditation Manager - Integral Energy
3.55 - 4.20	Proposed changes relating to services, Quality Assurance & developer charges	Ralph Miller, Senior Developer Policy Coordinator Sydney Water
4.25 - 4.50	Recent & proposed changes to procedures at the LTO, new Strata Titles Act & Sec 88K Electronic lodgement update	Graham Davies, Assist. Manager Plan Registration
4.55 - 5.05	Questions	Ron Sale, Land Titles Office
5.5 - 5.15	Close	
5.30 - 6.30	Happy Hour	

...000000000...

LIST OF 1997 EXHIBITORS

COMPANY	CONTACT	PHONE	FAX
CUMBERLAND GROUP	KEITH CADOGAN	9874 7674	
LAND INFORMATION CENTRE	JOHN KELLAGHER	9267 3982	
LAND TITLES OFFICE	FRANK MORGAN	9228 6832	
LEICA INSTRUMENTS	ALAN PATERSON	9888 7122	9888 7526
MAGELLAN GPS SYSTEMS	LUKE O'NEILL	9874 7233	9874 7851
MARC COMPUTER SERVICES P/L	MARC SACILOTTO	9630 8027	9630 2196
P.H.M. SURVEY EQUIPMENT	PAUL BARTON	9555 9175	9555 9187
PRECISION INSTRUMENTS	MARK BUCHANAN	9958 2866	9958 6998
SAGEM AUSTRALIA	LUKE TILYARD	9315 3500	9315 3555
SOKKIA	HUGH GERDES	9638 0055	9638 3933
TOPCON AUST P/L	PETER MCGURK	9817 4666	9817 0629

MEN, MARKS & MONUMENTS

A new surveying book is available today at the seminar.

"MEN, MARKS & MONUMENTS - A HISTORY OF SYDNEY SURVEYING 1830-1996"
written by Keith Cadogan is a history of surveying in the town of Sydney under the direction of the Colonial Government between 1830 and 1842 and then under the direction of the Municipal Government of the City of Sydney between 1842 and 1996.

After extensive researching and investigation, Keith has written a comprehensive and interesting chronicle of surveying in Sydney from the earliest days to the present time. Included are numerous photographs, sketches, plans and surprising amount of detail which is compulsive reading for anyone with an interest in surveying.

The production and promotion of this book is supported by the Cumberland Group of Surveyors, and distribution and promotion is supported by the Divisional Committee of the Institution of Surveyors New South Wales Incorporated.

Signed copies of the book are available today for \$10.

CUMBERLAND GROUP OF SURVEYORS

proudly presents

1998 DEVELOPMENT SEMINAR

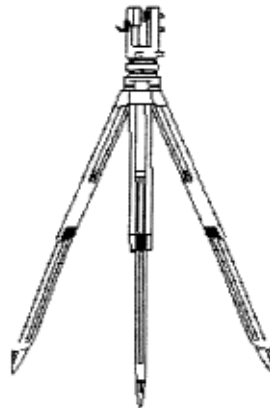

Held in the Kingfisher/Currawong/Kookaburra rooms of the Sunnybrook Travelodge
Cnr of Hume Highway and Liverpool Street, Warwick Farm.

Friday 26th of June, 1998

CUMBERLAND GROUP

Background

First formed in 1962 as a vehicle for local Surveyors to meet for fellowship and to exchange professional views, the Cumberland Group is one of the oldest such groups in New South Wales. Out of this group was also formed the Association of Consulting Surveyors (Australia) to specifically look after the needs of Consulting Surveyors in private practice.

In the early 70's under the Chairmanship of Bernie Moriarty and with Bert Cawthorne as Secretary, the Cumberland Group started organising guest speakers covering surveying related topics. Very soon the Group obtained a good reputation for organising successful and enjoyable meetings with interesting and informative speakers and this has been carried through to the seminar today.

The Cumberland Group still embodies the original aims and objectives as when it first began and meets every two months over dinner with guest speakers covering a wide range of topics from the latest legislation changes, development issues and other surveying related topics. We also hold a Ladies Night once a year with dinner and dancing at one of the local international hotels in the Parramatta area.

Our current venue for meetings is at the Parramatta Masonic Club, Parramatta. Membership is open to all financial members of the Institution of Surveyors and guests are also most welcome. For more information please phone (02) 9633-9211.

...ooo000ooo...

Today marks the eighth annual seminar that the Cumberland Group has presented. Our aim has always been to offer value for money seminars that are both informative and enjoyable. This years seminar has again proved popular with more than 300 registrants. As always we would welcome any constructive criticism or positive comments on your impressions on today's proceedings.

Following the tradition of our previous seminars, which have presented the planning policies and how things are intended to work, the focus of today's seminar is directed towards the practicalities and what happens in the 'real world'.

*After the seminar this year, the Cumberland Group is hosting its Annual Dinner with a special celebrity guest speaker
Mr. Peter FitzSimons*

We thank you for your participation today and trust that you will enjoy the proceedings and we look forward to seeing you again at our future seminars.

...ooo000ooo...

1998 Cumberland Group Committee:

Chairman: Roy Lowe

Secretary: Michael Parkinson

Treasurer: Gerard Junek

Greg Oxley, John Brock, Bob Hanna, Keith Cadogan, Ron Cumming, Brian McKinlay & Barry Yardley

TIMETABLE OF EVENTS

Development Seminar held on Friday, 26th of June 1998 held at the Sunnybrook Travelodge, Warwick Farm

Time		Speaker
8.00 - 8.45	Early morning tea/coffee	Trade displays & exhibitions
8.45 - 8.50	Welcome/Housekeeping	Roy Lowe, Cumberland Group Chairman
8.50 - 9.00	Opening Address	Allan Cavanagh, President IS - NSW Division
Session 1 <i>"Environmental & Cultural Issues Affecting Development"</i> <i>Introduced by Bob Hanna</i>		
9.00 - 9.20	Biodiversity Strategies and the Development Industry	Bob Lander, Landcom
9.20 - 9.40	Sustainable Development	Tony Proust, Newcastle City Council
9.40 - 10.00	The Assessment of Aboriginal & Social Issues Associated with Development	Neville Baker, Project Manager & Archaeologist from the Australian Museum
10.00 - 10.15	Questions	
10.15 - 10.20	Presentation of Exhibitors	
10.20 - 10.45	Morning Tea	
Session 2 <i>"New & Current Legislation"</i> <i>Introduced Greg Oxley</i>		
10.45 - 11.30	The Integrated Assessment Bill & New SEPP on Subdivision Standards	Kerrie Bedford, Manager Regulatory Reform Unit, DUAP
11.30 - 11.50	The Impact of the Bill & Implementation of Private Certification	Don Sheffield, MIE, MIEA
11.50 - 12.10	Preparation of DA's	Phil Mudge, Consultant
12.10 - 12.30	Questions	
12.30 - 1.45	Lunch	
Session 3 <i>"Stratum and Part Strata Schemes"</i> <i>Introduced by Michael Parkinson</i>		
1.45 - 2.05	Legal aspects of Stratum & Part Strata subdivisions	Laurie Ryan, Senior Legal Officer LTO & Author of Part Strata Legislation.
2.05 - 2.25	Plan preparation, easements & case studies	David Norris, Senior Plan Examiner LTO
2.25 - 2.45	Council's Perspective, case studies & common problems	Steve Longhurst, Surveyor Sydney City Council
2.45 - 3.00	Questions	
3.00 - 3.30	Afternoon Tea	
Session 4 <i>"LTO"</i> <i>Introduced by Roy Lowe</i>		
3.30 - 3.45	Opening address	David Mulcahy, Director LTO
3.45 - 4.10	Plan Processing & Electronic Plan Lodgement	Noel Benham, Manager Plan Registration Branch
4.10 - 4.35	Registrar General's Direction for Plans	David Norris, Senior Plan Examiner LTO
4.35 - 5.00	LTO's Accreditation of Surveyors in NSW	Des Chatwin, Deputy Director LTO
5.00 - 5.10	Questions	
5.10 - 5.15	Close	
5.30 - 6.30	Happy Hour	

...ooo0000ooo...

LIST OF 1998 EXHIBITORS

ORGANISATION	CONTACT	PHONE	FAX
INSTITUTION OF SURVEYORS	RICHARD PHILLIPS	9264 2076	9261 8102
LAND INFORMATION CENTRE	JOHN KELLAGHER	9267 3982	9267 4942
LAND TITLES OFFICE	NOEL BENHAM	9228 6832	9221 4405
LEICA INSTRUMENTS	ALAN PATERSON	9888 7122	9888 7526
MAGELLAN GPS SYSTEMS	LUKE O'NEILL	9874 7233	9874 7851
MARC COMPUTER SERVICES P/L	MARC SACILOTTO	9630 8927	9630 2196
PRECISION INSTRUMENTS	MARK BUCHANAN	9958 2866	9958 6998
SAGEM AUSTRALIA	LUKE TILYARD	9315 3500	9315 3555
SOKKIA	HUGH GERDES	9638 0055	9638 3933
TOPCON AJUST P/L	PETER MCGURK	9817 4866	9817 0629
LAWPOINT	PETER VOGT	9239 4999	9221 8671
LEGALCO	DENNIS CHISHOLM	9283 5111	9283 5333

MEN, MARKS & MONUMENTS

"MEN, MARKS & MONUMENTS - A HISTORY OF SYDNEY SURVEYING 1830-1996"
written by Keith Cadogan is a history of surveying in the town of Sydney under the direction of the Colonial Government between 1830 and 1842 and then under the direction of the Municipal Government of the City of Sydney between 1842 and 1996.

The production and promotion of this book is supported by the Cumberland Group of Surveyors, and distribution and promotion is supported by the Divisional Committee of the Institution of Surveyors New South Wales Incorporated.

Order your copy of the second print run from the Institution's display today!

HALLMANN LATEST RELEASE NOW ALSO ON CD-ROM

THE INSTITUTION OF SURVEYORS NSW INC. is proud to present *Legal Aspects of Boundary Surveying as Apply in NSW - Hallmann 2nd Edition on CD ROM!* Incorporating the 3rd release of updates for the 2nd Edition of Hallmann, the CD is in Adobe PDF format and includes "Adobe Acrobat Reader" to enable viewing on systems such as Windows 3.1; 95; NT; Macintosh; and a number of other formats. As an adjunct to the written version, this electronic document has been indexed to enable fast searching. If you have put off buying Hallmann before, why not consider purchasing one today so that all the up-to-date information on surveying is only a keystroke away!

The price for Institution members is still \$150.00 and you get both the loose leaf book and CD.
A demonstration of the new CD format is available at the Institution's display at the seminar today.

!!!CLEARANCE SALE!!!

INSTITUTION TIES

WE ARE TIRED OF THE OLD INSTITUTION TIE DESIGNS, BUT UNTIL WE CLEAR THE OLD STOCK, WE CAN'T ORDER ANYMORE. SO OUT THEY GO AT THE ONCE IN A LIFETIME PRICE OF \$5.00 EACH!!! THIS OFFER IS AVAILABLE FOR TODAY ONLY, SO SEE RICHARD OR HEATHER AT THE INSTITUTION'S DISPLAY AND SNAP UP A BARGAIN.

(VISA AND MASTERCARD ACCEPTED).

Figure 1. Extract from *The Australian Surveyor* September, 1963, pages iv and v.

**COLOUR
A DRAWING
WITH
THIS?**



IMPOSSIBLE!

Special tasks require special tools. The draftsman cannot use just any pencil, since normal coloured pencils cannot produce sharp lines.



The new plastic-lead **MARS-LUMOCHROM** from **STAEDTLER** is an economic help in improving and detailing technical drawings by the guiding element of colour. **MARS-LUMOCHROM** leads have these notable characteristics. **DURABILITY** and **BRILLIANCE**: Long-wearing with outstanding point-strength and consequently sharp, brilliantly-coloured lines. **CONSISTENCY**: All 24 colours have the same consistent hardness — no annoying variation when using a new shade. Easily and completely erasable. **REPRODUCTION**: Different colours print well in varying intensities to facilitate detailing of prints in original colour. **PERMANENCE**: Unaffected by water or perspiration, totally smearproof. Withstands repeated printing and sunlight. **VERSATILITY**: Recommended for use on tracing cloth and paper as well as drafting films. **MARS-LUMOCHROM** is the coloured companion of the famous **MARS-LUMOGRAPH**.

*Mars-Lumochrom Pencils, 24 single colours, set of 12's (No. 2617)
set of 24's (No. 265G)*

*Mars-Lumochrom Refill Leads, 13 single colours
Mars-Lumochrom Lead Holders for the 13-colour range of leads*



Post to **STAEDTLER-SOVEREIGN PTY. LTD.**, 140 PACIFIC HIGHWAY, GREENWICH, N.S.W.

Please send me descriptive literature on the **MARS** range together with samples of **MARS-LUMOCHROM** coloured drawing pencils.

Name.....

Firm.....

Turner
HAND TOOLS
AUSTRALIA

TURNER LUFKIN
GIVES YOU ONE MAN MEASURING



Illustration shows the barbed steel hook ring.

"Leader" Chrome clad Tapes available in the following lengths: 33', 66' and 100'.



It's true!—See the Hook Ring? With this aid you can check perimeters or measure the average block unassisted because the extra large barbed steel hook holds firm under tension . . . saves time on the job.

A Turner-Lufkin Chrome clad tape runs smoothly on nylon bearings, provides you with a line that stays true whatever the conditions. Even if you drop it in mud or water it won't crack or peel. It resists abrasion, rust and other forms of corrosion. Readings are pre-calculated at any point of measurement, the chance of error is eliminated.

Chrome clad tapes are available to you in the "Leader" with Hook Ring, "Wolverine" Engineer's Steel Tape and the "Mezurall" Tape-Rule — all handy items for your kit



"Wolverine" Engineer's Steel Tape available in 100' and 200' lengths — English, Decimal or Metric graduations.



"Mezurall" Chrome clad Tape Rule available in 6', 8', 10' and 12' lengths.



TURNER MANUFACTURING CO. PTY. LIMITED
BRANCH OFFICES IN ALL STATES
Better Products Through Better Research

Figure 2. Extract from *The Australian Surveyor* September, 1963, pages vi and vii.

AUTOMATIC ZEISS LEVEL



the principle



and application

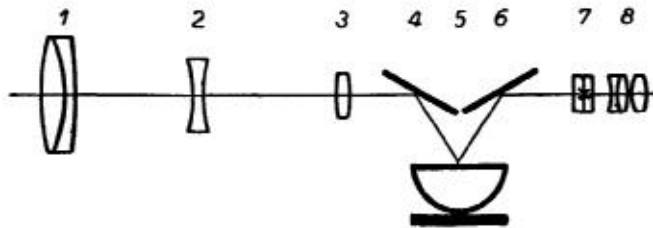

halves working time

CARL ZEISS PTY. LTD.

50 MILLER STREET, NORTH SYDNEY
N.S.W.

Phone: 92-0231

Sole Agents for CARL ZEISS, Oberkochen
West Germany

New British WATTS AUTOSET

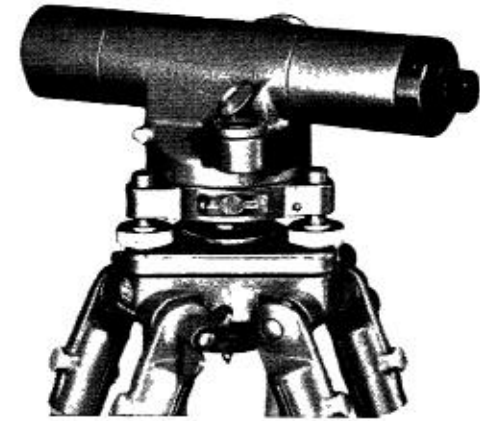

THE SELF-SETTING LEVEL

The Watts AutoSet self-setting level combines high accuracy with speed and ease of use.

Equipped with an optical stabiliser the Watts AutoSet is self-setting and maintains a level line of sight even when the telescope is tilted.

FAST

"setting-up" is eliminated and there is no need to reset the telescope for each reading.

ACCURATE

for work up to and including second order accuracy, using optical micrometer.

EASY

levelled to a circular bubble cup — no need to check each reading.

Complete data and specification details gladly sent upon request.

E. ESDAILE & SONS PTY. LTD.

31 BAY STREET, GLEBE, N.S.W. 68-5311
103 WAYMOUTH STREET, ADELAIDE, S.A. LA-6346-7

Figure 3. Extract from *The Australian Surveyor* December, 1963, pages ii and iii.

SURVEYING INSTRUMENTS AND ACCESSORIES



The fundamentals which go to make reliable surveying instruments are precision engineering combined with designs which, by experience, have proved to be the best. A careful choice of the most suitable materials and special consideration to reduction in weight, without sacrificing stability or strength, has established the high reputation now held by the well known maker,

Messrs. WILD HEERBRUGG, LTD., SWITZERLAND

Detailed information of their Theodolites, Levels and other allied equipment will be supplied on request.

We also Stock . . .

DRAWING INSTRUMENTS, SLIDE RULES, BINOCULARS, TELESCOPES, BAROMETERS, THERMOMETERS, "CURTA" UNIVERSAL CALCULATING MACHINES, MICROSCOPES and SCIENTIFIC BOOKS, etc.

N. H. SEWARD PTY. LTD.

457-9 Bourke Street, Melbourne, C.1

Telephone: MU 6129 (2 lines)

Cables & Telegrams: "SEWARDCO", Melbourne

Write or call for Price Lists

Repairs Promptly Executed

PHOTOGRAMMETRIC INSTRUMENTS

by

ZEISS

 AEROTOPOGRAPH

for

Photogrammetry and Air Photo Interpretation

ZEISS Stereopret for
Interpretation and Tracing

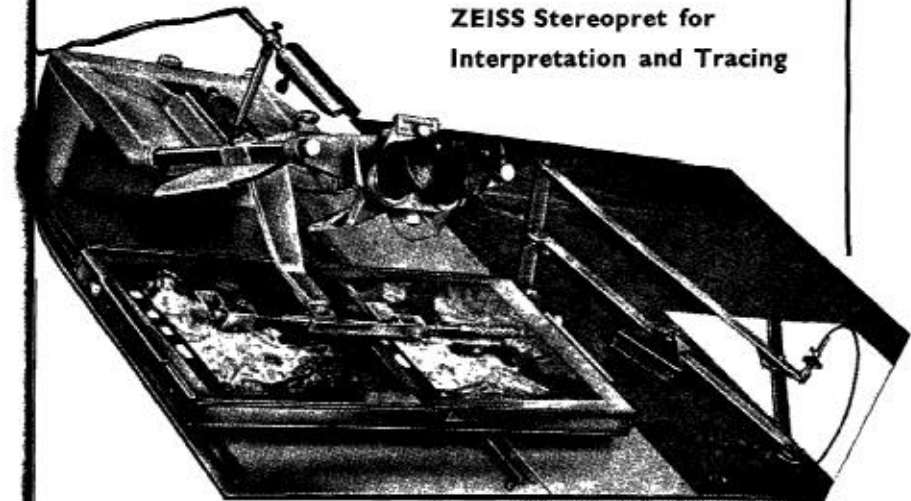

Pocket and Mirror Stereoscopes. Sketchmaster.
Radial Secator. Aerial Cameras. Stereotope.

Particulars and Literature from

ZEISS AEROTOPOGRAPH AGENTS :-

PRECISION INSTRUMENT CO. PTY. LTD.

88-90 WALKER STREET, NORTH SYDNEY. 92-4280

HERGA & CO.; 181 Edward Street, Brisbane. 2 4824

DOBBIE BROS.; 173 Exhibition Street, Melbourne

GRANTHAM LTD., 67 Eton Road, Sommerton Park, S.A.

Figure 4. Extract from *The Australian Surveyor*, December, 1963 pages vi and vii.

New
British
WATTS
AUTOSET

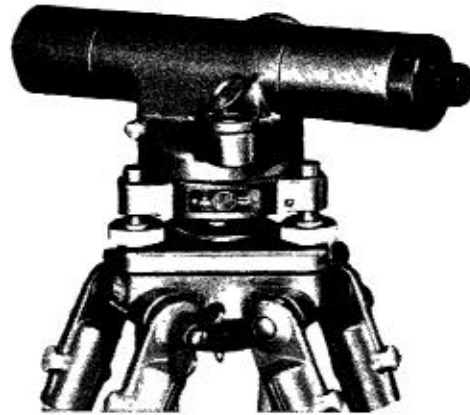

THE SELF-SETTING LEVEL

The Watts Autaset self-setting level combines high accuracy with speed and ease of use.

Equipped with an optical stabiliser the Watts Autaset is self-setting and maintains a level line of sight even when the telescope is tilted.

FAST "setting-up" is eliminated and there is no need to reset the telescope for each reading.

ACCURATE for work up to an including second order accuracy, using optical micrometer.

EASY levelled to a circular bubble cup — no need to check each reading.

Complete data and specification details gladly sent upon request

E. ESDAILE & SONS PTY. LTD.

31 BAY STREET, GLEBE, N.S.W. 68-5311

103 WAYMOUTH STREET, ADELAIDE, S.A. . . LA-6346-7

Cooke Troughton & Simms
LTD

S 700

SPEED
WITH ACCURACY

**SELF-
ALIGNING
LEVEL**

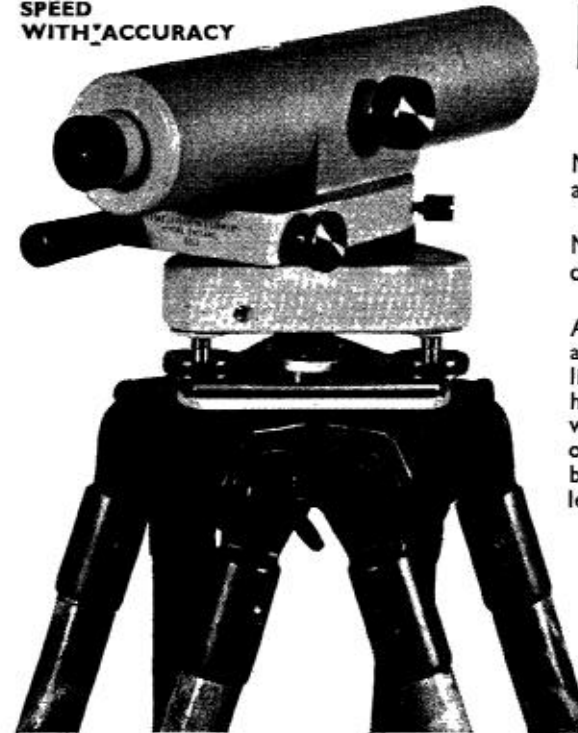

No main spirit vial to adjust.

No micrometer screw to operate.

A compensating device automatically keeps the line of sight in a horizontal plane to within 1 second of arc once the instrument has been approximately levelled.

Distributor in Victoria

A. E. PARSONS

18 - 20 LITTLE LATROBE STREET
MELBOURNE, C.I.

Phone: FJ 4084

Surveying and Scientific Instrument Maker

Chain Bands, Staves, Bubbles, etc., manufactured to order

Repairs promptly attended to

Figure 5. Extract from *The Australian Surveyor*, December 1963, pages viii and ix.

A NEW "HOLBRO" PRODUCT— the "MUDLARK" Metal Levelling Staff

Made in three folding sections of Aluminium alloy with a Silver Anodised finish.



The following are the principal features of the "Mudlark" Staff:

- Method of hingeing the sections (patent applied for).
- Speed of erection. Merely open the sections out and push together.
- The three sections of the Staff are hinged, but each section is also detachable, which allows the two lower sections or bottom section only to be used when the full length is not required.
- Painted face accurately and clearly graduated.
- Fitted with folding handles and recessed circular spirit level.
- When the Staff is folded the face is completely protected.

The "Mudlark" Staff is designed to withstand climatic conditions detrimental to a wooden staff and is ideal for working in water.

Co-efficient of Expansion. Linear expansion equals $L \times 23 \times 10^{-6}/^{\circ}\text{C}$.

In Six Sizes

Size extended

14 ft.

16 ft.

6 ft.

9 ft.

3 metres

4 metres

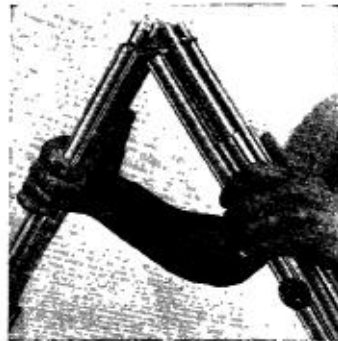

HOLMES BROS. (LONDON) LTD., LEYTON, LONDON, E. 10

AUSTRALIAN AGENTS

SYDNEY:

E. Esdaile & Sons (Pty.) Ltd.
Precision Instrument Co. (Pty.) Ltd.
WILD (Australia) Pty. Ltd.

BRISBANE:

The Instrument Engineering (Pty.) Ltd.
Herga & Co.
The Greenfield Instrument Co.

TASMANIA:

J. Welch & Sons Pty. Ltd.

MELBOURNE:

A. G. Barker & Assoc. Pty. Ltd.
A. E. Parsons
Thomas Optical & Scientific Co. Pty. Ltd.

PERTH:

MacDougall Pty. Ltd.

ADELAIDE:

Boettgers
E. Trelliving & Sons Ltd.

WATTS

SURVEYING, ENGINEERING & PHOTOGRAMMETRIC
INSTRUMENTS

Latest

MICROPTIC THEODOLITE ST-156

The new model Watts ST-156 Microptic Theodolite has higher power telescope, $\times 25$.

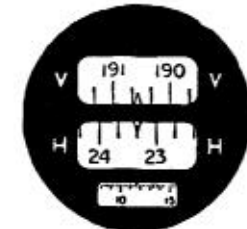
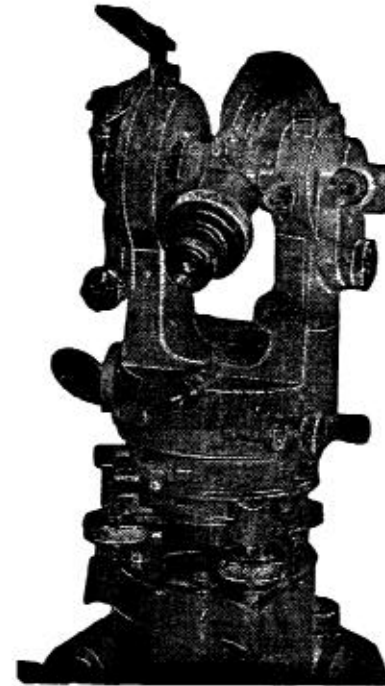

Horizontal Circle Reading
Circle $23^{\circ} 20'$
Micrometer $11' 40''$
 $23^{\circ} 31' 40''$

PHOTOGRAMMETRIC INSTRUMENTS

Thompson-Watts First Order Plotter — Watts Radial
Line Plotter — for speedy transfer of detail from
photo to map.

HILGER & WATTS LTD. (WATTS DIVISION)

98 ST. PANCRAS WAY, CAMDEN LANE, LONDON, W.1

Australian Agents:

N.S.W. and Federal Territories: E. Esdaile & Sons Pty. Ltd., Sydney.
Victoria: Thomas Optical Co. Pty. Ltd., Melbourne. **Queensland:** Herga & Co., Brisbane. **Tasmania:** Waterworth & Aves, Hobart. **West Australia:** MacDougall Pty. Ltd., Perth. **South Australia:** E. Esdaile & Sons Pty. Ltd., Adelaide.



Figure 6. Vern Clements, 'then'.



Figure 7. Vern Clements, 'now'.

?

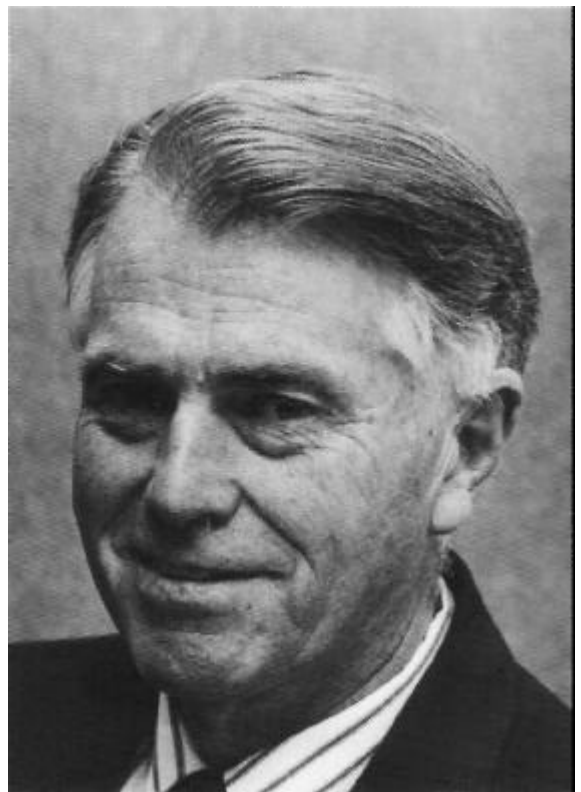

Figure 9. Barry McLeod, 1993.



Figure 10. Bert & Betty Cawthorne, 1997.

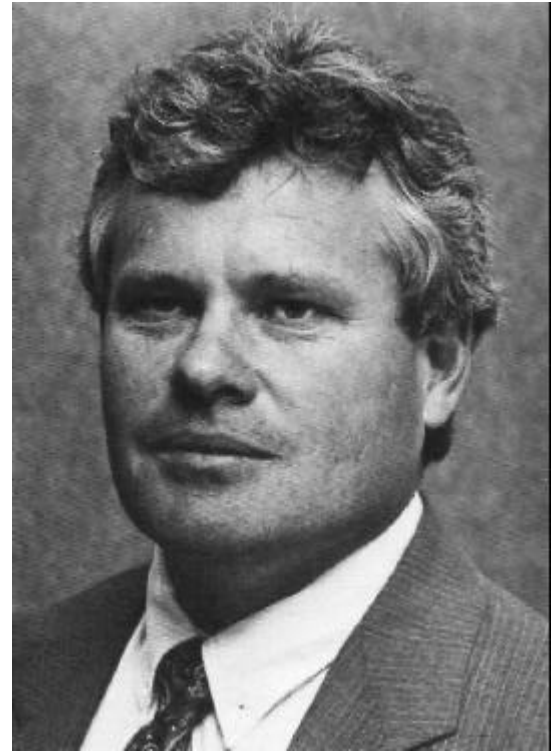

Figure 11. Bill Backhouse, 1994/1995.



Figure 12. Cumberland Group Committee, 1997.

From left: John Brock; Barry Yardley; Brian McKinlay; Keith Cadogan; Bob Hanna (Treasurer); Gerard Junek; Greg Oxley; Michael Parkinson (Secretary); Roy Lowe (Chairman); Ron Cumming.